

Water Booster Station

Submittal for SCADA Panel

Prepared by:

Your Company

Your Address

Panel Job: 2012-398

Table of Contents

- A. Datasheets - Enclosures / Accessories**
- B. Datasheets - Power / Control Components**
- C. Datasheets - Field Mounted Components**
- D. Drawings**
- E. Bill of Materials**



Application

Designed to protect electrical and electronic controls, components, and instruments in typical industrial environments. The Type 12 rating protects enclosed equipment from dust, dirt, oil, and dripping water. These enclosures are used in machine tool applications for housing motor starters, drives, contactors, PLCs, as well as a wide variety of other electrical and electronic equipment. The addition of 19-inch rack mounting accessories make these enclosures ideal for providing rugged protection for sensitive rack mounted components in harsh industrial environments. The enclosures are found extensively in automotive, pulp and paper, wood products, textile, and similar industries. Four styles are available to provide maximum flexibility:

1. Single-Door Single Access Enclosures (single door on front)
2. Single-Door Dual Access Enclosures (single door on front and rear)
3. Two-Door Single Access Enclosures (overlapping doors on front)
4. Two-Door Dual Access Enclosures (overlapping doors on front and rear)

Construction

- 12 gauge steel (backs of two-door single access enclosures are 10 gauge steel)
- Seams continuously welded and ground smooth, no holes or knockouts
- Stiffeners welded to back of two-door enclosures maintain flatness and increase rigidity
- Lifting eyes for easy handling
- 3-point latching operated by oil-tight key-locking handle
- Latch rods have rollers for easier door closing
- Heavy gauge continuous hinges support each door
- Data pocket, provided on door(s) with 3-point latches, is high-impact thermoplastic
- Mounting channels welded horizontally to interior body sides at top, bottom, and center
- Optional panels and rack mounting angles can be mounted anywhere along channels
- Oil-resistant door gasket attached with oil-resistant adhesive and held in place with steel retaining strips
- Grounding stud on door
- Provision for mounting fluorescent light

Finish

White inside with ANSI 61 gray outside finish over phosphatized surfaces. Optional panels, swing-out panels, side mounted panels, rack mounting frames, heavy duty panel supports and center panel supports are white.

Industry Standards

UL 508, File No. E61997, Type 12
 NEMA/EEMAC Type 12
 E.I.A. RS-310-D
 CSA, File No. LR42186, Type 12
 IEC 60529, IP65

Accessories

See *General Accessories index*

Blower Package
 Casters
 Clamping Nut Kit
 Corrosion Inhibitors
 Electric Heaters
 Electrical Interlocks
 Fan Cooling Products
 Floor Stand Kit
 Folding Shelf
 Keyboard Kit
 Lighting Kit
 Panel Support Kit
 Panels
 Touch-Up Paint (A-TPG15GLS)
 Window Kit
 Wiring Duct

Modification Services™ Program

You can customize this product to your unique requirements by specifying from these options:

- Enclosure height, width, depth
- Over 100 standard finish colors and textures
- Holes and cutouts in body, doors, subpanels
- Tapped holes, fasteners, mounting channel in enclosure or subpanel
- Mounting
- Doors
- Subpanels
- Structural changes
- Environmental control (louvers, fans, filters)
- Windows
- Standard accessories

For details, see Modification Services at hoffmanonline.com.

To order, contact your local Hoffman sales representative.

Free-Standing Enclosure Group Accessory Selection Guide See General Accessories, Section 11

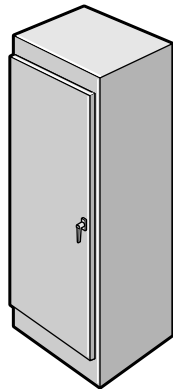

Free-Standing Type 12 Single-Door Enclosure
(Single Access or Dual Access)

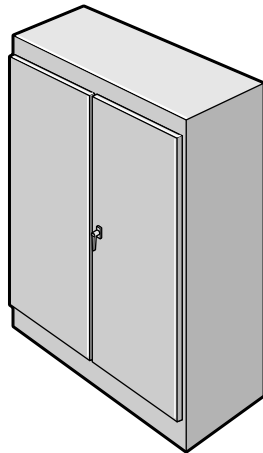

Free-Standing Type 12 Two-Door Enclosure
(Single Access or Dual Access)

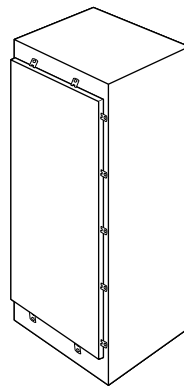

Free-Standing Type 4 Enclosure

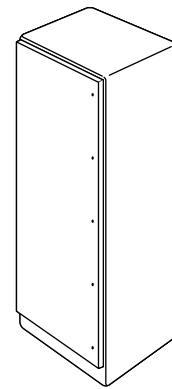

Free-Standing Fiberglass Type 4X Enclosure

Internal Accessories

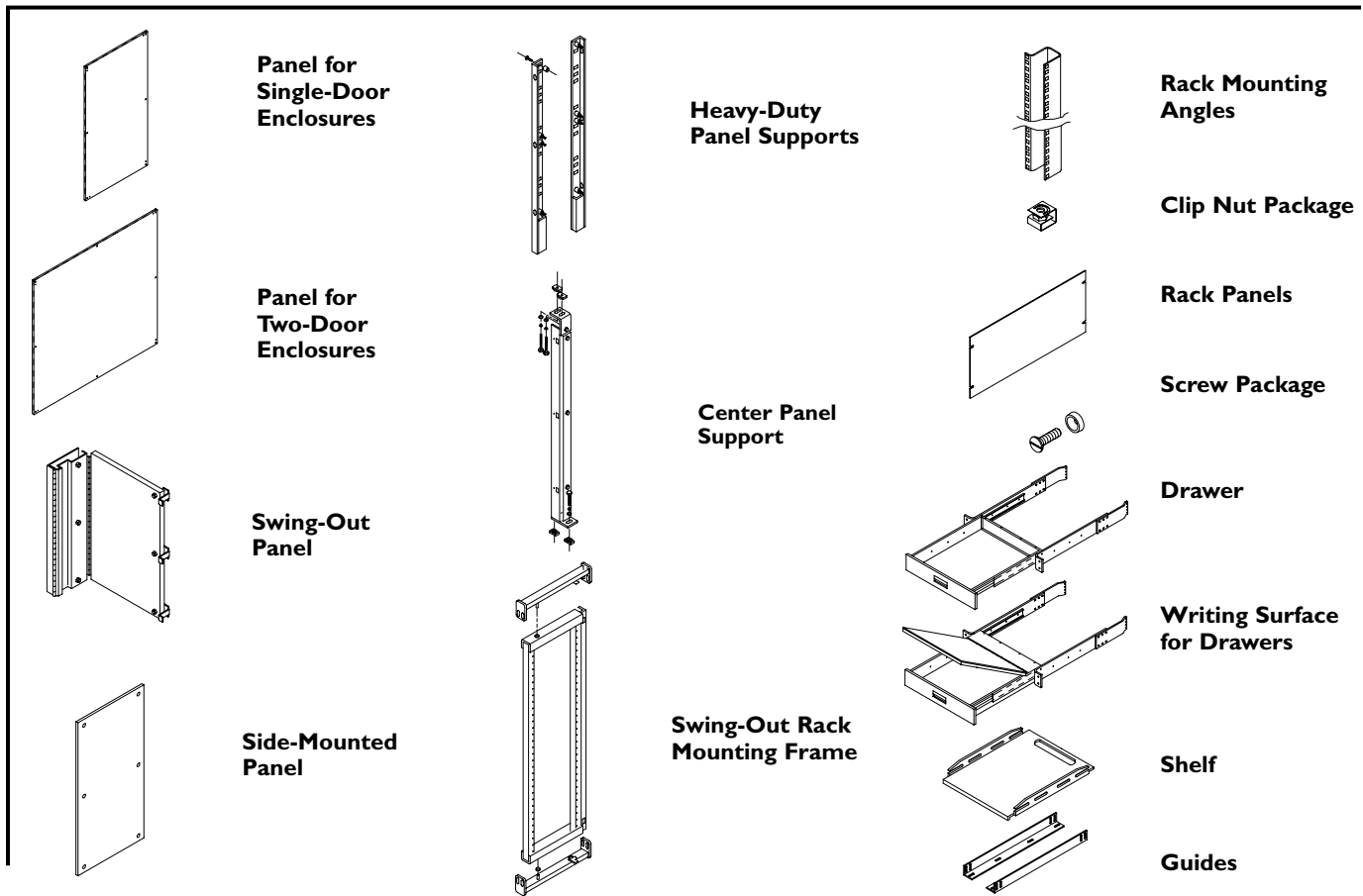

To select an accessory for the enclosure, see the following Free-Standing Enclosure Accessory tables

C2586

Two-Door Single Access

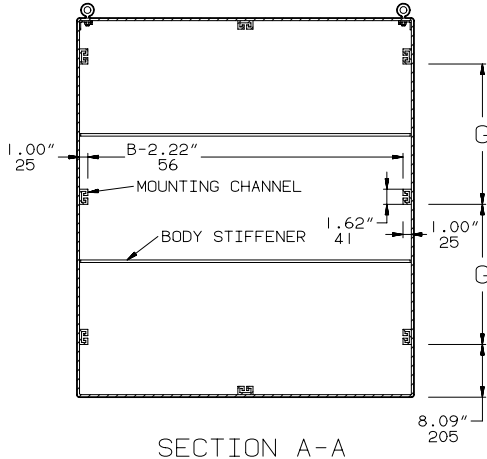
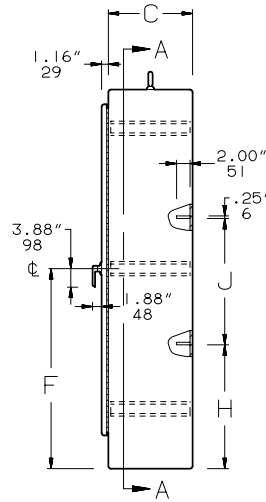
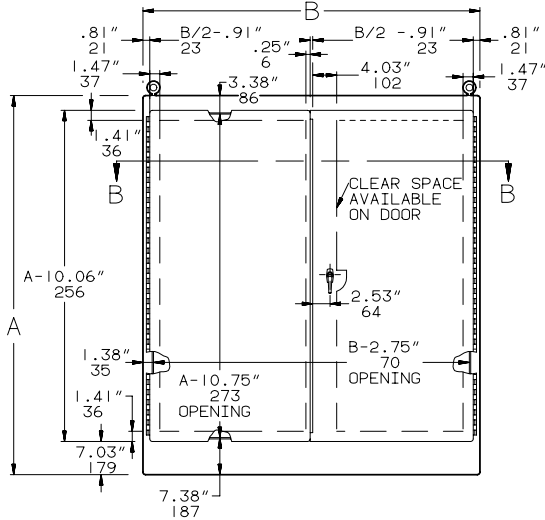

C2489-1

- NOTE:
1. Four lifting eyes are furnished if $C = 30.06$ (764) or more.
 2. See General Accessories for section views A-A and B-B showing accessories.
 3. Removable 12.00x12.00 (305x305) data pocket.

Inch
Millimeter

Standard Sizes Two-Door Single Access Free-Standing Type 12 Enclosures

Enclosure Catalog Number	Enclosure Size A x B x C		F	G	H	J
	inch	(millimeter)				
A-604818FSD	60.06 x 48.06 x 18.06	(1526 x 1221 x 472)	32.03	23.12	19.88	20.03
A-724818FSD	72.06 x 48.06 x 18.06	(1830 x 1221 x 472)	38.03	29.12	23.88	24.03
A-726018FSD	72.06 x 60.06 x 18.06	(1830 x 1526 x 472)	38.03	29.12	23.88	24.03
A-727218FSD	72.06 x 72.06 x 18.06	(1830 x 1830 x 472)	38.03	29.12	23.88	24.03
A-904820FSD	90.06 x 48.06 x 20.06	(2288 x 1221 x 510)	47.03	38.12	29.88	30.03
A-907220FSD	90.06 x 72.06 x 20.06	(2288 x 1830 x 510)	47.03	38.12	29.88	30.03
A-724824FSD	72.06 x 48.06 x 24.06	(1830 x 1221 x 611)	38.03	29.12	23.88	24.03
A-726024FSD	72.06 x 60.06 x 24.06	(1830 x 1526 x 611)	38.03	29.12	23.88	24.03
A-727224FSD	72.06 x 72.06 x 24.06	(1830 x 1830 x 611)	38.03	29.12	23.88	24.03
A-907224FSD	90.06 x 72.06 x 24.06	(2288 x 1830 x 611)	47.03	38.12	29.88	30.03
A-726036FSD	72.06 x 60.06 x 36.06	(1830 x 1526 x 916)	38.03	29.12	23.88	24.03
A-907236FSD	90.06 x 72.06 x 36.06	(2288 x 1830 x 916)	47.03	38.12	29.88	30.03

Millimeter dimensions () are for reference only; do not convert metric dimensions to inch.



How It Works

Each inhibitor contains a special chemical combination that vaporizes and condenses on all surfaces in an enclosed area. Vapors will redeposit as needed in the event of condensation of moisture on surfaces. These vapors reach every part of an enclosure, protecting all interior components. Spraying, wiping, or greasing are not required. This eliminates pre-coating, special wraps, and drying agents. Protection is effective even in salt water atmospheres. The A-HCI5E and A-HCI10E emitters have additional red metal inhibitors for further protection. Enclosures containing corrosion inhibitors must be reasonably sealed.

Life Expectancy and Usage

The normal useful life-span of Hoffman corrosion inhibitors is in excess of one year. However, inhibitor life expectancy is shortened by approximately 25% when exposed to temperatures above 104° F (40°C).

This product is not recommended for use where temperature exceeds 199°F. Ventilated enclosures or enclosures not sealed properly as well as frequent door openings also shorten the product life. Additional inhibitors should be used if these conditions exist. Since Hoffman corrosion inhibitors are vapor phase protective, all surfaces to be protected should be accessible to the vapors. The maximum distance the vapors can travel is approximately 1.50 feet (.46 meters). Protection of long narrow enclosures can be achieved with tape or multiple inhibitors.

Storage and Handling

Each Hoffman corrosion inhibitor is individually packaged in a resealable bag for maximum effectiveness at time of usage. Corrosion inhibitors should be stored at temperatures not exceeding 120°F (45°C). Recommended shelf life under normal conditions is one year. Hoffman corrosion inhibitors are not returnable.

When determining the proper corrosion inhibitor for your application, assume that the enclosure volume to be protected is greater than calculated if (1) cabinet doors are opened frequently, (2) cabinet is located in an extremely corrosive area, and/or (3) cabinet length divided by depth is greater than four.

AHCI1DV Foam device protects one cubic foot (28 liters) of enclosure volume for approximately one year.

Size: .25" x 1.25" x 3.00"
(6mm x 32mm x 76mm)

AHCI60R Tape protects sixty cubic feet of enclosure volume per roll. Use approximately 2.50" (6.3cm) of tape per cubic foot (28 liters) of enclosure volume to be protected. Each roll of tape is packaged individually in a resealable bag.

Size: .25" x .75" x 12.00"
(6mm x 19mm x 3.6m)

AHCI240R Tape protects 240 cubic feet of enclosure volume per roll. Use approximately 1.00" (2.5cm) of tape per cubic foot (28 liters) of enclosure volume to be protected. Each roll of tape is packaged individually in a resealable bag.

Size: .25" x 2.00" x 20.00"
(6mm x 51mm x 6.1m)

AHCI5E Emitter protects five cubic feet (142 liters) of enclosure volume for approximately one year. Emitters contain additional red metal (non-ferrous) inhibitors.

Size: 2.50" (diameter) x 1.50" (high)
(63mm x 38mm)

AHCI10E Emitter protects ten cubic feet (283 liters) of enclosure volume for approximately one year. Emitters contain additional red metal (non-ferrous) inhibitors.

Size: 2.50" (diameter) x 2.00" (high)
(63mm x 51mm)

AHCI238S Spray is a non-conductive, nonflammable, vapor phase film and is non-toxic. It has essentially neutral pH value. Application provides instant protection against corrosion. Spray is water soluble and can be easily flushed away with water if desired. This product should be kept from freezing, and has a shelf life of 2+ years in normal warehouse conditions.

Industrial Corrosion Inhibitors

Hoffman corrosion inhibitors protect

- Interior components of electrical enclosures, boxes, consoles, and wireways
- Interior components of electronic enclosures
- Electrical and electronic equipment and controls
- Parts and components that are packaged in crates during shipping and storage
- Switch gear and relay cabinets
- Interiors of pipes, conduits, and fuse boxes
- Process control computers, instruments, and recording devices
- Tool chest interiors and contents
- Equipment stored at construction sites

Chief Advantages

- Protects against salt and high humidity
- Eliminates the need of oiling, plating, or dipping metal
- Puts protected equipment to use immediately without degreasing or coating removal
- Provides durable protection for up to 12 months

Metal	Protected by Chemical	Unprotected by Chemical
Aluminum	Marked reduction of surface attack; no pitting	Severe surface attack; tarnish; pitting
* Brass	Decreased tarnish; very minor surface attack	Surface discoloration; pitting
Steel, Iron	No change	Severe corrosion
* Copper	Slight staining	Heavy corrosive attack
Zinc Plate	Slight discoloration	Severe corrosion
Tin Plate	Slight discoloration	Moderate corrosive attack

Catalog Number	Enclosure Volume Protected
AHCI1DV	1 cu. ft. (28.32 liters)
AHCI5E	5 cu. ft. (141.6 liters)
AHCI10E	10 cu. ft. (283.2 liters)
AHCI60R	60 cu. ft. pr. roll (1699 liters)
AHCI240R	240 cu. ft. pr. roll (6797 liters)
AHCI238S	(Corrosion Inhibitor Spray)

* AHC15E and AHC10E emitters are recommended for these materials.

Lighting Packages

LED Light Kit



LED light kits provide interior enclosure lighting. These light kits are ideal for remote and darkened enclosure applications. The light can be mechanically fastened with included hardware to maintain enclosure UL listing (up to Type 4X), or can be magnetically attached to flat steel surfaces. The lights have auto-sensing circuitry (AC voltage 90 VAC to 260 VAC and DC voltage 20 VDC to 60 VDC). LED lights are light-weight and in a small form factor while providing 900 LM of 6500K light.

Bulletin: A80LT

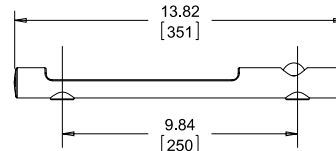

Motion Sensor Light

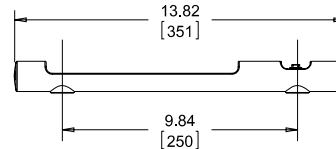
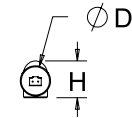

On/Off Switch Light

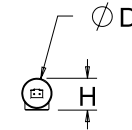

89090091

Catalog Number	AxBxC in./mm	Weight (oz)	Weight (gm)	Mounting Style	Power Source	Activation	Voltage
LEDA1M35	1.34 x 1.26 x 13.82 34 x 32 x 351	4.8	135	Magnetic	AC	On/off switch	90 VAC-260 VAC
LEDA2M35	1.54 x 1.26 x 13.82 39 x 32 x 351	5.0	140	Magnetic	AC	IR Motion Sensor	90 VAC-260 VAC
LEDA1S35	1.42 x 2.05 x 13.82 36 x 52 x 351	4.8	135	Screw	AC	On/off switch	90 VAC-260 VAC
LEDA2S35	1.63 x 2.05 x 13.82 41 x 52 x 351	5.0	140	Screw	AC	IR Motion Sensor	90 VAC-260 VAC
LEDD1M35	1.34 x 1.26 x 13.82 34 x 32 x 351	4.8	135	Magnetic	DC	On/off switch	20 VDC-60 VDC
LEDD2M35	1.54 x 1.26 x 13.82 39 x 32 x 351	5.0	140	Magnetic	DC	IR Motion Sensor	20 VDC-60 VDC
LEDD1S35	1.42 x 2.05 x 13.82 36 x 52 x 351	4.8	135	Screw	DC	On/off switch	20 VDC-60 VDC
LEDD2S35	1.63 x 2.05 x 13.82 41 x 52 x 351	5.0	140	Screw	DC	IR Motion Sensor	20 VDC-60 VDC

LED Light Input Connector/Cable Assembly



The input connector/cable assembly is used to provide supply power to the LED light. Pre-assembled connector/cable assembly with 78.7-

in. (2000 mm) long cable whip. Cables are constructed of 16 AWG copper wire.

Bulletin: A80LT

Catalog Number	A in./mm	Power Source	Use with
LEDA20C	78.74 2000	AC	AC LED Lights
LEDD20C	78.74 2000	DC	DC LED Lights

LED Light Extension Connector/Cable Assembly



The extension connector/cable assembly is used to connect adjacent LED lights (daisy chain). Up to 10 LED lights can be ganged or

connected in series. Pre-assembled connector/cable assembly with 39.4-in. (1000 mm) long cable between input and output connectors. Cables are constructed of 16 AWG copper wire.

Bulletin: A80LT

Catalog Number	A in./mm	Power Source	Use with
LEDA10E	39.37 1000	AC	AC LED Lights
LEDD10E	39.37 1000	DC	DC LED Lights

Lighting Packages

Remote Door Switches



- Remote door switch activates the light when the enclosure door is opened
- Mounts on enclosure frame and includes mounting hardware
- Mounting plate is 14 gauge steel with a plated finish
- Can be hard-wired to the PANELITE LED or Fluorescent light or connected via the PANELITE Door Switch Cable

Bulletin: A80LT, P20

Catalog Number	Description
ALFSWD	Door switch assembly (order connection cable separately)
PLFSWD	Door switch assembly for PROLINE™ (order connection cable separately)

Touch-Safe UL Light Switch

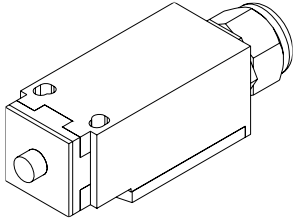

Application

The Touch-Safe light switch is designed to be used with Hoffman™ light kits (AC and DC). It provides a UL listed touch-safe switch that can be used on many enclosure types and includes hardware for most applications. The light switch maintains enclosure overall rating up to UL 508A Type 4X or 12.

Features

- UL listed for a touch-safe wire connection
- Easily mounted to various enclosure types; common bracket and hardware included for many enclosure types (NEMA, CONCEPT™ / FUSION™ G7, PROLINE™, Freestanding Type 12)
- Cable PG compression hub
- Wide operating temperature range: -49°F to +158°F (-45°C to 70°C)
- Rugged die-cast anodized zinc construction
- Connection 3 cage clamps for solid and stranded wire AWG 20-14 (0.5-2.5mm²)
- Protection class I (grounded)

Catalog Number	Max. Cable Dia.	Max. Voltage
LDSWITCH	.375 in.	250 AC / 48 DC

Mounting Bracket Kit for Light Package

Kit simplifies mounting light package in Hoffman PROLINE™ disconnect enclosures. Includes brackets, all mounting hardware and complete instructions.

Bulletin: A80LT

Catalog Number	Description
PDLFBRKT	Mounting Bracket Kit

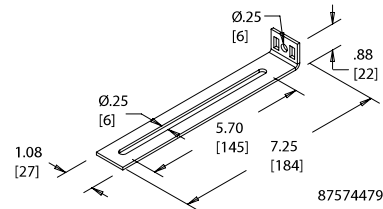

EMC-240B



The EMC is a rugged highly reliable panel surge protector for residential or commercial standard 120/240V single or split phase applications.

The EMC features totally solid state construction for reliability and quick response to surges. Two advanced, metal oxide varistors (MOV) are the primary protective elements. These MOV's are each capable of 40,000 Amps of surge current.

The protection components are designed to fail shorted and are fused. After a surge, the suppressor automatically recovers and is ready for the next surge. In a rare event of MOV failure, the fuse opens and the indicator LED extinguishes.

SPECIFICATIONS

Response Time	<5 nanoseconds
Maximum Surge Current	40,000 Amps/phase
Max. Energy Absorption (2ms)	360 Joules per phase
Initial Clamping Voltage	240 Volts Nominal
Clamp Voltage @ 300A	395 Volts Nominal
Max. Allowable Voltage (L-N)	150 Vrms 50-60 Hz
Max. Allowable Voltage (L-L)	275 V rms 50-60Hz
Failure Mode	Failsafe (short) and Fused
Failure Indication	LED Indicators
Surge Life @ 10,000A	>50 Occurrences
Size	4.5" x 2.8" x 2.2"
Operational Temp.	-40°C to +85°C

FEATURES

- Fast Response Time
- No Holdover or Follow Current
- 40,000 Amps per phase capacity
- Failsafe and fused
- Operational status indicators
- UL 1449 Listed



TYPICAL INSTALLATION

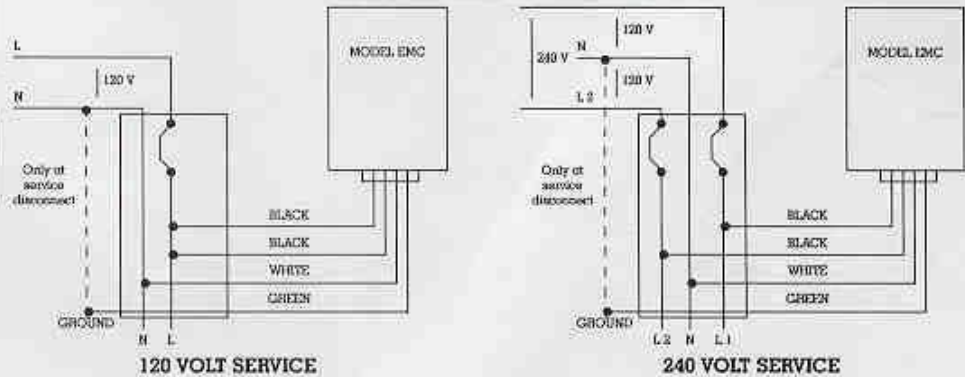

MECHANICAL SPECIFICATIONS

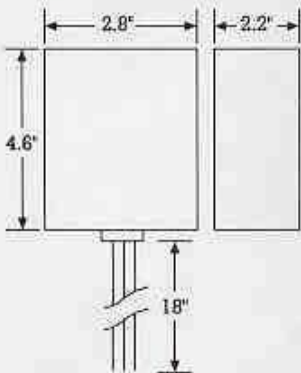

CAUTION

1. Installation and Service should be performed by qualified electricians only.
2. Before installing EMC, remove all electrical power from circuits.
3. Install EMC on load side of breaker(s) as shown.

DIN-Rail Mounted Maintenance Outlets

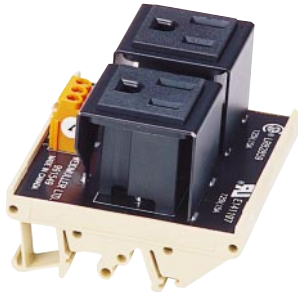

These modules are intended for use in control cabinets as 120 VAC outlets for power tools, lights, test equipment, computers, etc.

Two versions are available - a single outlet with feedthrough terminals for the AC power (the 120 V enters the modules, powers the outlet, and is available on a separate group of terminals for powering other devices), and a duplex version.

Features

- Power outlet 15 A
- TS 32 and TS 35 DIN-rail mounted
- UL and CSA approved

Simplex

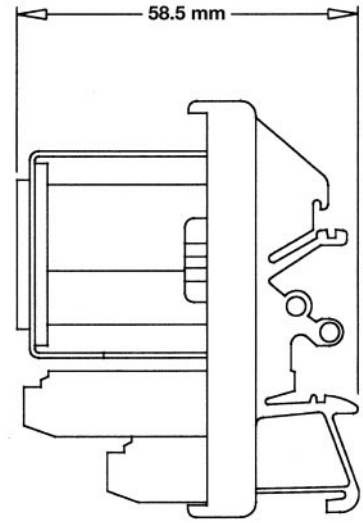
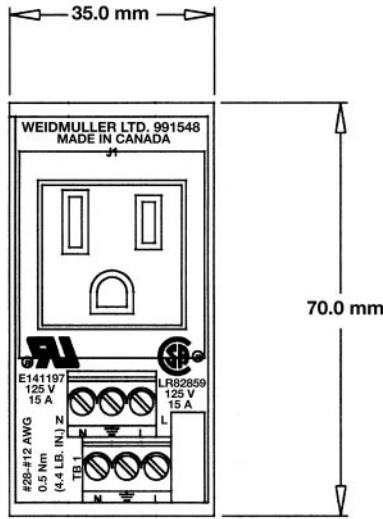

Duplex

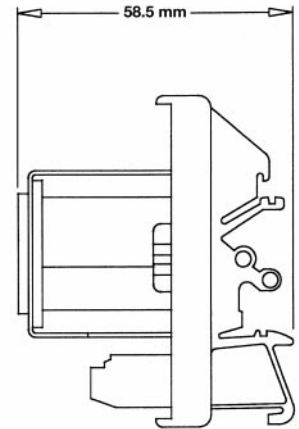
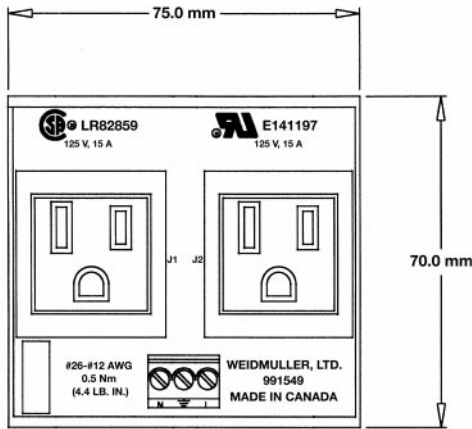

CABLE INTERFACE ACCESSORIES

Ordering Data

Type	Part No.
RS Simplex 120 V Single Outlet	991548
RS Duplex 120 V Dual Outlet	991549



Bulletin 1489-A Circuit Breakers

- Energy-limiting design — protects downstream components better than conventional breakers during short circuits
- Field-mountable options for selective applications
- IP2x Finger-Protection (Front)
- North America certifications: UL 489, CSA C22.2 No. 5
- International standards: CE Marked, and IEC (VDE) standards for worldwide acceptance
- Ratings: UL/CSA — max. 480Y/277V AC – up to 14 kA interrupt rating;
IEC — max. 240/415V AC – 15 000 A interrupt rating
- 48V DC rating, 96V DC — 2-pole series
- A positively trip-free mechanism (breaker operation cannot be defeated by holding the handle in the ON position)
- Trip curves: C and D
- Time delay (D Characteristic) for high inrush currents during inductive start-ups such as motors, transformers and power supplies
- Superior shock and vibration resistance capabilities — helps to prevent nuisance tripping
- Mounts on DIN Rail
- Wire connect, line and load (reversible)
- Optional terminals for ring lug terminals

Table of Contents

Specifications..... 13
 Description 3
 Product Selection 9
 Approximate Dimensions..... 14

Standards Compliance

UL 489
 CSA C22.2 No. 5
 EN/IEC 60947-2

Certifications

UL Listed
 CSA Certified
 CE Marked
 VDE Certified

Industrial Circuit Breakers for North American Applications

The Bulletin 1489-A line includes:

- UL 489, CSA C22.2 No. 5
- 240V AC 0.5...40 A
- 480V/277V AC 0.5...32 A
- Miniature Circuit Breaker for EN/IEC Applications
EN/IEC 60947-2
415V AC 0.5...40 A
- SWD (0.5...20 A) Switching Duty for fluorescent lighting applications
- HACR
- 1-pole 48V DC 0.5...40 A
- 2-pole (series) 96V DC 0.5...40 A
- 48V DC 0.5...40 A

Description

Bulletin 1489-A Circuit Breakers for Branch Circuit protection are available in 1-, 2-, and 3-pole construction and are rated 0.5...40 A at 240V AC and 0.5...32 A at 480Y/277V AC for North American applications (UL 489 and CSA C22.2 No. 5). The circuit breakers also have a 1-pole 48V DC, 2-pole (series) 96V DC rating. For EN/IEC applications the products are rated 415V AC, 48V AC 0.5...40 A.

Thermal Magnetic Circuit Breakers

The Bulletin 1489-A Thermal Magnetic Circuit Breakers are general-purpose devices suitable for the majority of industrial, inverse time circuit breaker applications.

They combine thermal and magnetic trip actions and provide accurate overload and short-circuit protection for conductors and connected equipment.

Circuit Breaker Application Information

Selection of a Bulletin 1489 circuit breaker with appropriate circuit protection includes consideration of:

- Circuit Voltage
- Circuit Frequency
- Available Short Circuit Current
- Continuous Current Rating
- Application Considerations
- Special Operating Conditions

The following discussion is based upon National Electric Code and UL requirements. Similar considerations are appropriate for Canadian applications.

Features

- Designed manufactured and listed to UL 489 (CSA 22.2 No. 5)
- Thermal-magnetic protection
- All ratings are HACR rated
- up to 14 kA Interrupting rating
- Finger-safe design (front)
- DIN Rail mounting
- Line and load wire connections
- Optional ring terminal connections (convertible)

Circuit Voltage

The Bulletin 1489-A circuit breakers are rated by voltage class. Applications should not exceed the listed voltage and current range (see Table 1).

Circuit Frequency

The Bulletin 1489-A circuit breakers may be applied to frequencies of 50 Hz and 60 Hz without derating. For applications above 60 Hz, contact Rockwell Automation with specific application information for the derating of the circuit breakers.

Available Short Circuit Current

The Bulletin 1489-A circuit breakers should only be applied in those applications in which the available short-circuit (or fault) current is less than or equal to 10 kA...14 kA (US/Canada) and 15 kA (IEC).

Table 1. Voltage and Current Ranges

Region	Max. Voltage	Current Range [A]
EN/IEC Regions	415V AC	0.5...40
	48V DC	0.5...40
North America (UL 489 & CSA C22.2 No. 5)	240V AC	0.5...40
	480Y/277V AC	0.5...32
	1-pole 48V DC	0.5...40
	2-pole 96V DC	0.5...40

Product Selection

Bulletin 1489-A AC Miniature Circuit Breakers

Bulletin 1489 1-Pole AC Miniature Circuit Breakers

No. of Poles	EN/IEC Maximum Voltage	Trip Curve	UL/CSA Max. Volt.	Rated Current [A]	Standard Wire Configuration Cat. No.	Ring Terminal Configuration Cat. No.				
1	415V AC, 48V DC	C	277V AC, 48V DC	0.5	1489-A1C005	1489-A1C005R				
				1	1489-A1C010	1489-A1C010R				
				1.5	1489-A1C015	1489-A1C015R				
				2	1489-A1C020	1489-A1C020R				
				3	1489-A1C030	1489-A1C030R				
				4	1489-A1C040	1489-A1C040R				
				5	1489-A1C050	1489-A1C050R				
				6	1489-A1C060	1489-A1C060R				
				7	1489-A1C070	1489-A1C070R				
				8	1489-A1C080	1489-A1C080R				
				10	1489-A1C100	1489-A1C100R				
				13	1489-A1C130	1489-A1C130R				
				15	1489-A1C150	1489-A1C150R				
				16	1489-A1C160	1489-A1C160R				
				20	1489-A1C200	1489-A1C200R				
				25	1489-A1C250	1489-A1C250R				
				30	1489-A1C300	1489-A1C300R				
				32	1489-A1C320	1489-A1C320R				
							240V AC, 48V DC	35	1489-A1C350	1489-A1C350R
								40	1489-A1C400	1489-A1C400R
				D	277V AC, 48V DC	0.5	1489-A1D005	1489-A1D005R		
						1	1489-A1D010	1489-A1D010R		
						1.5	1489-A1D015	1489-A1D015R		
						2	1489-A1D020	1489-A1D020R		
						3	1489-A1D030	1489-A1D030R		
						4	1489-A1D040	1489-A1D040R		
						5	1489-A1D050	1489-A1D050R		
						6	1489-A1D060	1489-A1D060R		
						7	1489-A1D070	1489-A1D070R		
						8	1489-A1D080	1489-A1D080R		
						10	1489-A1D100	1489-A1D100R		
						13	1489-A1D130	1489-A1D130R		
						15	1489-A1D150	1489-A1D150R		
						16	1489-A1D160	1489-A1D160R		
						20	1489-A1D200	1489-A1D200R		
						25	1489-A1D250	1489-A1D250R		
						30	1489-A1D300	1489-A1D300R		
						32	1489-A1D320	1489-A1D320R		
							240V AC, 48V DC	35	1489-A1D350	1489-A1D350R
								40	1489-A1D400	1489-A1D400R

You are here: [Home](#) > [Products](#) > [Uninterruptible Power Supply \(UPS\)](#) > [Network and Server](#) > [Smart-UPS](#)



APC Smart-UPS XL Modular 1500VA 120V Rackmount/Tower

Part Number: SUM1500RML2U



[Technical Specifications](#) [Product Overview](#) [Documentation](#) [Software & Firmware](#) [Options](#)

Output

Output Power Capacity 1425 Watts / 1440 VA

Max Configurable Power 1425 Watts / 1440 VA

Nominal Output Voltage 120V

Topology Line Interactive

Output Connections (8) NEMA 5-15R



Bypass Internal Bypass (Automatic and Manual)

Input

Nominal Input Voltage 120V

Input Frequency 50/60 Hz +/- 3 Hz (auto sensing)

Input Connections NEMA 5-15P



Cord Length 10 feet (3.05 meters)

Input voltage range for main operations 82 - 147V

Input voltage adjustable range for mains operation 75 - 154V

Batteries & Runtime

Battery Type VRLA

Typical recharge time 3 hour(s)

Replacement Battery [RBC43](#)

RBC™ Quantity 1

Extended Run Options [APC Smart-UPS XL Modular 1500VA 120V Rackmount/Tower](#)

Runtime Graph

Curve	Part Number(s)
A	SUM1500RML2U
B	SUM1500RML2U + (1)SUM48RMLBP2U
C	SUM1500RML2U + (2)SUM48RMLBP2U
D	SUM1500RML2U + (3)SUM48RMLBP2U
E	SUM1500RML2U + (4)SUM48RMLBP2U

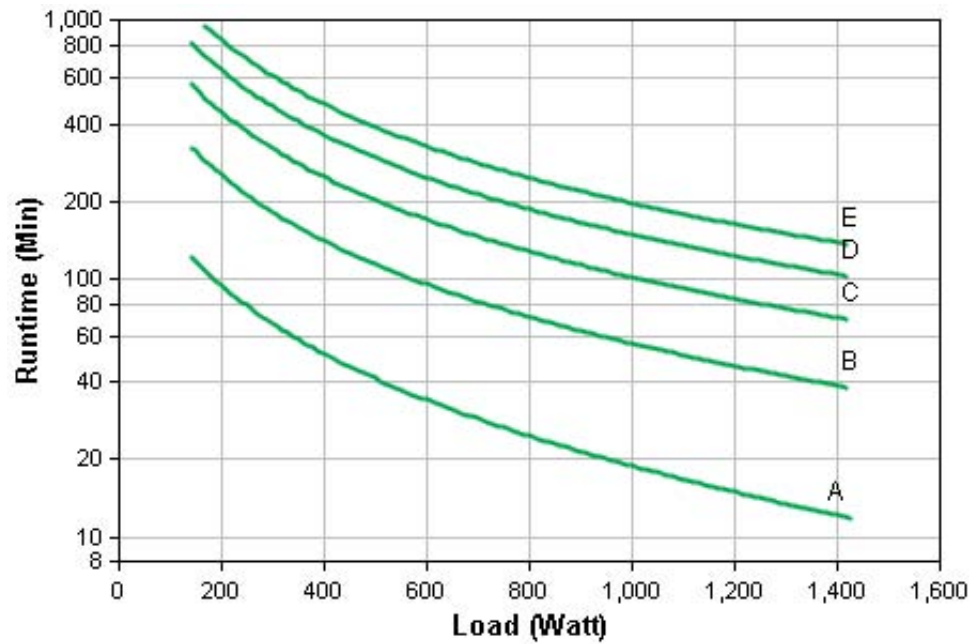

Hover over the line on the graph above to view the runtime at any desired load

Curve fit to measured runtime data. All measurements taken with new, fully charged batteries, at typical environmental conditions, with no electrical input and balanced resistive load (PF = 1.0) output.

[View Enlarged Graph](#)

[View Runtime Chart](#)

Energy Use/Efficiency

Load	Efficiency
25%	92.0%
50%	95.2%
75%	95.9%
100%	96.0%

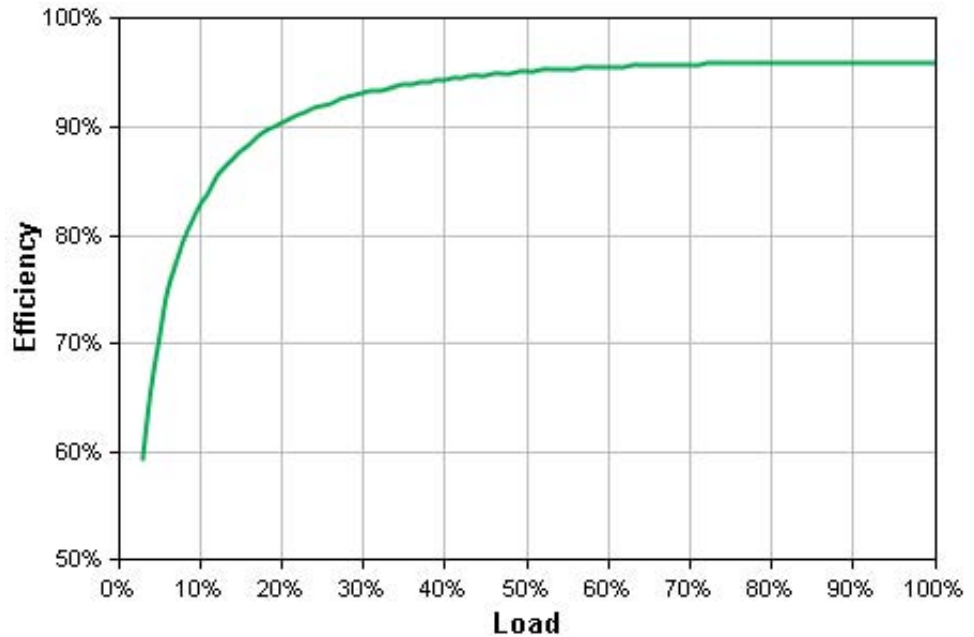

Hover over the line on the graph above to view the efficiency at any desired load

Curve fit to measured efficiency data. All measurements taken in normal operating mode, at typical environmental conditions, with nominal electrical input and balanced resistive load (PF = 1.0) output.

[View Enlarged Graph](#)

Communications & Management

Interface Port(s)	DB-9 RS-232, RJ-45 10/100 Base-T, USB
Pre-Installed SmartSlot™ Cards	AP9631
Control panel	LED status display with load and battery bar-graphs and On Line : On Battery : Replace Battery : Overload and Bypass Indicators
Audible Alarm	Alarm when on battery : distinctive low battery alarm : configurable delays
Emergency Power Off (EPO)	Optional

Surge Protection and Filtering

Surge energy rating	540 Joules
Filtering	Full time multi-pole noise filtering : 0.3% IEEE surge let-through : zero clamping response time : meets UL 1449

Physical

Maximum Height	3.40 inches (86 mm)
Maximum Width	17.00 inches (432 mm)
Maximum Depth	26.70 inches (678 mm)
Rack Height	2U
Net Weight	103.00 lbs. (46.82 kg)
Shipping Weight	125.00 lbs. (56.82 kg)
Shipping Height	9.84 inches (250 mm)

Shipping Width	23.46 inches (596 mm)
Shipping Depth	38.58 inches (980 mm)
Color	Black
Units per Pallet	8.00

Environmental

Operating Environment	32 - 104 °F (0 - 40 °C)
Operating Relative Humidity	0 - 95%
Operating Elevation	0-10000 feet (0-3000 meters)
Storage Temperature	23 - 131 °F (-5 - 55 °C)
Storage Relative Humidity	0 - 95%
Storage Elevation	0-30000 feet (0-9000 meters)
Audible noise at 1 meter from surface of unit	55.00 dBA
Online Thermal Dissipation	300.00 BTU/hr

Conformance

Regulatory Approvals	BSMI, CSA, FCC Part 15 Class A, NOM, UL 1778, VCCI
Standard Warranty	2 years repair or replace
Equipment protection policy	Lifetime : \$150000

Sustainable Offer Status

RoHS	Compliant
PEP	Available in Documentation tab
EOLI	Available in Documentation tab

*Except where noted, all prices are Estimated Resale Price (ERP) - Without Tax/VAT. Pricing in other locations and sites may vary.

**The time to recharge to 90% of full battery capacity following a discharge to shutdown using a load rated for 1/2 the full load rating of the UPS.

Power Cords

Assembled Connectors

K515PASSM

KC13ASSM

Assembled plug heads allow for quick modifications on our power cords. Standard cords are manufactured using molded plugs.

Stock No.	Mfr.'s Type	Description	EACH
			1-99
592-5150	K515PASSM KC13ASSM	Assembled 5-15P Plug	3.72
592-0133		Assembled C13 Connector	2.41

5-15P Plug to Pigtail Power Cords

24130-67-01

- ▶ All Cords Are Three Conductor
- ▶ All Cords Are UL Approved
- ▶ All Power Cords Are Available with Shielded Cordage
- ▶ All Power Cords Are Available in High Temp — 105°C By Special Order, Minimums May Apply

Stock No.	Mfr.'s Type	AWG	Cordage	Length	NEMA Plug	IEC Connector	Amp Rating @ 125 VAC	EACH
								1-99
592-2237	28230-60-01	18	SVT	6' 0"	5-15P	C-13	10	3.05
592-2232	28130-60-01	18	SJT	6' 0"	5-15P	C-13	10	3.33
592-2230	28130-67-01	18	SJT	6' 7"	5-15P	C-13	10	4.43
592-2235	28230-67-01	18	SVT	6' 7"	5-15P	C-13	10	1.83
592-2238	28230-80-01	18	SVT	8' 0"	5-15P	C-13	10	2.37
592-2233	28130-80-01	18	SJT	8' 0"	5-15P	C-13	10	3.24
592-2236	28230-910-01	18	SVT	9' 10"	5-15P	C-13	10	4.65
592-2231	28130-910-01	18	SJT	9' 10"	5-15P	C-13	10	3.44
592-2224	26130-67-01	16	SJT	6' 7"	5-15P	C-13	13	4.66
592-2225	26130-910-01	16	SJT	9' 10"	5-15P	C-13	13	4.81
592-2222	24130-67-01	14	SJT	6' 7"	5-15P	C-13	15	6.42
592-2223	24130-910-01	14	SJT	9' 10"	5-15P	C-13	15	9.20

5-15P Plug to C-13 Connector Power Cords

24131-67-01

- ▶ All Cords Are Three Conductor
- ▶ All Cords Are UL Approved
- ▶ All Power Cords Are Available with Shielded Cordage
- ▶ All Power Cords Are Available in High Temp — 105°C By Special Order, Minimums May Apply

Stock No.	Mfr.'s Type	AWG	Cordage	Length	NEMA Plug	IEC Connector	Amp Rating @ 125 VAC	EACH
								1-99
592-2246	28131-67-01	18	SJT	6' 7"	5-15P	C-13	10	2.85
592-0058	28131-76-01	18	SJT	7' 6"	5-15P	C-13	10	3.11
592-2250	28231-76-01	18	SVT	7' 6"	5-15P	C-13	10	2.89
592-2249	28131-910-01	18	SJT	9' 10"	5-15P	C-13	10	3.72
592-2242	26131-67-01	16	SJT	6' 7"	5-15P	C-13	13	3.50
592-2243	26131-76-01	16	SJT	7' 6"	5-15P	C-13	13	3.66
592-2244	26131-910-01	16	SJT	9' 10"	5-15P	C-13	13	4.89
592-2240	24131-67-01	14	SJT	6' 7"	5-15P	C-13	15	5.45
592-2241	24131-910-01	14	SJT	9' 10"	5-15P	C-13	15	5.89

Manufacturing Capabilities

Features Available

- ▶ International Power Cords
- ▶ International Approvals
- ▶ International Plugs and Connectors
- ▶ All Cords Are UL Approved
- ▶ Shielded or Unshielded Cordage
- ▶ North American or European Color Code
- ▶ 2 or 3 Conductors
- ▶ Choice of 7 Wire Sizes
- ▶ Choice of 7 Cord Types
- ▶ Molded Plug Heads and Connectors
- ▶ 105°C Cords
- ▶ Hospital Grade Cords
- ▶ Any Custom Cord with a 300 Piece Minimum
- ▶ Other Standard Plugs and Terminations Available
- ▶ The Letter "T" in a Power Cord Part Number Indicates High Temperature Cordage (105°C)

Available Gauges

- ▶ 12 Gauge
- ▶ 14 Gauge
- ▶ 16 Gauge
- ▶ 18 Gauge
- ▶ 0.75 mm
- ▶ 1.0 mm
- ▶ 1.5 mm

Available Cord Types

- ▶ SJT
- ▶ SVT
- ▶ SPT-1
- ▶ SJO
- ▶ H03VV-F
- ▶ H03VVH2-F
- ▶ H05VV-F
- ▶ Other Types Available Upon Request

International Approvals

- ▶ Australia
- ▶ Austria
- ▶ Belgium
- ▶ Canada
- ▶ Denmark
- ▶ Finland
- ▶ France
- ▶ Germany
- ▶ Italy
- ▶ Japan
- ▶ Netherlands
- ▶ Norway
- ▶ Sweden
- ▶ Switzerland
- ▶ United Kingdom
- ▶ United States

5-15P Plug to Right Angle C-13 Connector Power Cords

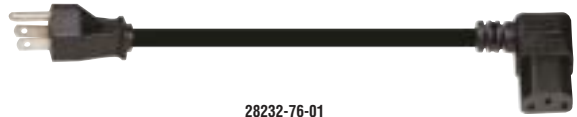
28232-76-01

- ▶ All Cords Are Three Conductor
- ▶ All Cords Are UL Approved
- ▶ All Power Cords Are Available with Shielded Cordage
- ▶ All Power Cords Are Available in High Temp — 105°C By Special Order, Minimums May Apply

Stock No.	Mfr.'s Type	AWG	Cordage	Cord Length	NEMA Plug	IEC Connector	Amp Rating @ 125 VAC	EACH
								1-99
592-2253	28232-76-01	18	SVT	7' 6"	5-15P	C-13	10	3.29
592-2255	28132-76-01	18	SJT	7' 6"	5-15P	C-13	10	3.50
592-2254	26132-76-01	16	SJT	7' 6"	5-15P	C-13	13	4.33

C-14 to Straight C-13 Power Cords

26171-33-01

- ▶ All Cords Are Three Conductor
- ▶ All Cords Are UL Approved
- ▶ All Power Cords Are Available with Shielded Cordage
- ▶ All Power Cords Are Available in High Temp — 105°C By Special Order, Minimums May Apply

Stock No.	Mfr.'s Type	AWG	Cordage	Cord Length	NEMA Plug	IEC Connector	Amp Rating @ 125 VAC	EACH
								1-99
592-2817	28171-33-01	18	SJT	3' 3"	C-14	C-13	10	4.16
592-2617	26171-33-01	16	SJT	3' 3"	C-14	C-13	13	2.77
592-2827	26171-67-01	16	SJT	6' 7"	C-14	C-13	13	3.16
592-2627	26171-910-01	16	SJT	9' 10"	C-14	C-13	13	8.38

Hospital Grade 5-15P Plug to C-13 Connector Power Cords

28151-80-03

- ▶ All Cords Are Three Conductor
- ▶ All Cords Are UL Approved
- ▶ All Power Cords Are Available with Shielded Cordage
- ▶ All Power Cords Are Available in High Temp — 105°C By Special Order, Minimums May Apply

Stock No.	Mfr.'s Type	AWG	Cordage	Cord Length	NEMA Plug	IEC Connector	Amp Rating @ 125 VAC	EACH
								1-99
592-2260	28151-80-03	18	SJT	8'	5-15P Clear	C-13	10	7.77
592-2262	28161-80-03	18	SJT	8'	5-15P	C-13	10	7.77
592-2261	28151-100-03	18	SJT	10'	5-15P Clear	C-13	10	7.98
592-2263	28161-100-03	18	SJT	10'	5-15P	C-13	10	7.98
592-2615	26151-80-03	16	SJT	8'	5-15P Clear	C-13	13	7.77
592-2616	26151-100-03	16	SJT	10'	5-15P Clear	C-13	13	7.98
592-2626	26161-100-03	16	SJT	10'	5-15P	C-13	13	7.98
592-2636	26161-140-03	16	SJT	14'	5-15P	C-13	13	8.73

International Power Cord

2880825-01

- ▶ European Style Cord

Stock No.	Mfr.'s Type	AWG	Cord Type	Length	NEMA Plug	Amp Rating @ 250 VAC	EACH
592-2882	2880825-01	18	H05V V-F	2.5 M	010A	10	5.63

[You are here: Home](#) > [Products](#) > [Uninterruptible Power Supply \(UPS\)](#) > [UPS Management](#) > [Additional Management Cards and Options](#)



Dry Contact I/O SmartSlot Card

Part Number: AP9613



[Technical Specifications](#) [Product Overview](#) [Documentation](#) [Options](#)

Physical

Net Weight	0.46 lbs. (0.21 kg)
Maximum Height	1.50 inches (38 mm)
Maximum Width	4.75 inches (121 mm)
Maximum Depth	4.50 inches (114 mm)
Shipping Weight	0.88 lbs. (0.40 kg)
Shipping Height	2.00 inches (51 mm)
Shipping Width	9.25 inches (235 mm)
Shipping Depth	6.25 inches (159 mm)
Color	Black
Units per Pallet	896.00

Environmental

Operating Environment	32 - 104 °F (0 - 40 °C)
Storage Temperature	5 - 149 °F (-15 - 65 °C)
Operating Relative Humidity	0 - 95%
Storage Relative Humidity	0 - 95%
Operating Elevation	0-10000 feet (0-3000 meters)
Storage Elevation	0-50000 feet (0-15000 meters)

Conformance

Regulatory Approvals	EN 55022 Class A, EN 55024, EN 61000-3-2, EN 61000-3-3, EN61000-4-2, EN61000-4-3, EN61000-4-4, EN61000-4-6, FCC Part 15 Class A
----------------------	---

Standard Warranty	2 years repair or replace
-------------------	---------------------------

Equipment protection policy	--
-----------------------------	----

Sustainable Offer Status

RoHS	Compliant
------	-----------

REACH	REACH: Contains No SVHCs
-------	--------------------------

Other Environmental Compliance	China RoHS
--------------------------------	------------

*Except where noted, all prices are Estimated Resale Price (ERP) - Without Tax/VAT. Pricing in other locations and sites may vary.



Eaton FlexPDU and Maintenance Bypass PDU

Eaton provides five different functions for rack power distribution solutions. Two of these functions, FlexPDU and Maintenance Bypass PDU, were created as accessories specific to some of our UPSs. Both of these units offer the flexibility of connections to meet the demanding requirements of today's data center architects.

The HotSwap Maintenance Bypass (MBP) unit enables easy UPS replacement without interruption of the load. The HotSwap MBP is ideal when exchanging a unit or servicing a UPS. For added convenience, the HotSwap MBP offers two types of receptacles: 5-15R or 5-20R.

The FlexPDU is a basic function power distribution unit with a short power cord for easy, close mounting. FlexPDUs are available with 5-15R, 5-20R or L5-20R output receptacles, for connection to a wide range of equipment.

Both of these options allow for easy deployment, even in space-constrained environments. You have a variety of mounting options, including top and side mounting.

Features

- HotSwap MBP provides service continuity during UPS maintenance or upgrade
- Both units offer connections to all types of equipment
- Eases installation with flexible mounting options
- Minimal depth accommodates most space constraints



Side mounting Flex PDU with Tower UPS



Top mounting horizontal FlexPDU with 2U UPS



HotSwap MBPs rackmounted horizontally in rack



Top mounting vertical FlexPDU



Powering Business Worldwide

FLEXPDU MODELS

Catalog number	Style Number	Input Plug	Breaker	Max kW	Function	Cord (ft)	Orientation	Receptacles	Dimensions (H x W x D, in)
EFLXL1500R-PDU1U	58015	5-15P	None	1.44	BA	3	1U	(12) 5-15R	1.7 x 19.0 x 2.4
EFLXL2000R-PDU1U	58020	5-20P	None	1.92	BA	3	1U	(12) 5-20R	1.7 x 19.0 x 2.4
EFLXL2000R-PDU1UL	58021	5-20P	None	1.92	BA	3	1U	(5) L5-20R	1.7 x 19.0 x 3.0
EFLXI3000R-PDU1UIEC	68438	C20 Inlet	(2) 20A	3.33	BA	3	1U	(12) C13, (1) C19	1.7 x 19.0 x 2.4

HOTSWAP MODELS

Catalog number	Style Number	Input Plug	Breaker	Max kW	Function	Cord (ft)	Orientation	Receptacles	Dimensions (H x W x D, in)
EHBPL1500R-PDU1U	58115	5-15P	None	1.44	BA	8	2U	(6) 5-15R	2.1 x 17.3 x 3.8
EHBPL2000R-PDU1U	58120	5-20P	None	1.92	BA	8	2U	(6) 5-15R	2.1 x 17.3 x 3.8
EHBPL3000R-PDU1U	58130	L5-30P	(2) 20A	2.88	BA	3.3	2U	(5) 5-20R	2.1 x 17.3 x 3.8

COMPATIBILITY MATRIX FOR RACKMOUNT UPSs*

FlexPDU plug/amp rating	UPS model (North American only)	Rack mounting	Rear mounting**	Side mounting	Top mounting
15A	Eaton Evolution Rack UPS, 650–1550 VA	✓			
	Eaton Evolution S Rack/Tower UPS, 1250 VA	✓		✓	✓
	Eaton 5130 Rack/Tower UPS, 1000–1500 VA	✓		✓	✓
	Eaton 5PX UPS, 1000 and 1500 VA	✓		✓	✓
	Eaton 9130 Rack UPS, 700–1500 VA	✓			
	Eaton EX Rack UPS, 1000–1500 VA	✓			✓
20A, 20A Locking	Eaton Evolution Rack/Tower UPS, 2000 VA	✓			
	Eaton Evolution S Rack/Tower UPS, 1750 VA	✓	✓	✓	✓
	Eaton 5130 Rack/Tower UPS, 2200 VA	✓	✓	✓	✓
	Eaton 5PX UPS, 2200 VA	✓	✓	✓	✓
	Eaton 9130 Rack UPS, 2000–3000 VA	✓			
	Eaton EX Rack/Tower UPS, 2200–3000 VA	✓	✓	✓	✓

*For tower models, all FlexPDUs can be wall-mounted. **Rear mounting available on 3U models only.

HotSwap MBP plug/amp rating	UPS model (North American only)	Rack mounting	Rear mounting**	Side mounting	Top mounting
15A	Eaton Evolution Rack UPS, 650–1550 VA	✓			
	Eaton Evolution S Rack/Tower UPS, 1250 VA	✓		✓	✓
	Eaton 5130 Rack/Tower UPS, 1000–1500 VA	✓		✓	✓
	Eaton 5PX UPS, 1000 and 1500 VA	✓		✓	✓
	Eaton 9130 Rack UPS, 700–1500 VA	✓			
	Eaton EX Rack UPS, 1000–1500 VA	✓			✓
20A	Eaton Evolution Rack/Tower UPS, 2000 VA	✓			
	Eaton Evolution S Rack/Tower UPS, 1750 VA	✓		✓	✓
	Eaton 5130 Rack/Tower UPS, 2200 VA	✓		✓	✓
	Eaton 5PX UPS, 2200 VA	✓		✓	✓
	Eaton 9130 Rack UPS, 2000 VA	✓			
	Eaton EX Rack/Tower UPS, 2200 VA	✓	✓	✓	✓
30A	Eaton Evolution S Rack/Tower UPS, 2500–3000 VA	✓	✓	✓	✓
	Eaton 5130 Rack/Tower UPS, 3000 VA	✓	✓	✓	✓
	Eaton 5PX UPS, 3000 VA	✓	✓	✓	✓
	Eaton 9130 Rack UPS, 2500–3000 VA	✓			
	Eaton EX Rack/Tower UPS, 3000 VA	✓	✓	✓	✓

*For tower models, all HotSwap MBPs can be wall-mounted. **Rear mounting available on 3U models only.

To interact with the FlexPDU and Maintenance Bypass PDU, please visit: eaton.com/epdu

Eaton Corporation
8609 Six Forks Road
Raleigh, NC 27615
United States
800.356.5794

Eaton.com/powerquality

©2011 Eaton Corporation
All Rights Reserved
Printed in USA
PDU17FXA
November 2011

Eaton is a registered trademark of Eaton Corporation.

All other trademarks are property of their respective owners.



1606-XLP Compact — Single- and Two-Phase
Single-Phase

Input Voltage	Output Power [W]	Output Voltage	Output Current [A]	Input Circuit Protection	Steady State Input Current 120/230 [V AC]	Parallel Operation	DC OK Relay	Cat. No.
100...240V AC, 85...375V DC	15	5...5.5	3	10 A Slow Blow Fuse or Cat. No. 1489-A1C100/ 15 A*	0.28/.017	Yes	—	1606-XLP15A
		12...15	1.3		0.28/.017		—	1606-XLP15B
		24...28	0.6		0.28/.017		—	1606-XLP15E
	25	5...5.5	5		0.60/0.30	Yes	—	1606-XLP25A
		10...12	3		0.60/0.25	Yes	—	1606-XLP30B
	30	24...28	1.3		0.60/0.35		—	1606-XLP30E
		54	12...15		4.5		0.54/0.30	—
	36	+/- 12/15V	2.8		0.65/0.40	No	—	1606-XLP36C
	50	12...15	4.2		1.00/0.60	Yes	—	1606-XLP50B
		24...28	2.1		0.77/0.44	Yes	—	1606-XLP50E
		24...28	2.1		1.00/0.60	Yes	—	1606-XLP50EZ
		48...56	1		1.00/0.60	Yes	—	1606-XLP50F
	54	12...15	4.5		0.91/0.54	Yes	—	1606-XLP60BQ
	54	12...15	4.5		0.97/0.61	Yes	—	1606-XLP60BQT
	60	24...48	2.1		0.98/0.58	Yes	—	1606-XLP60EQ
60	24...48	2.1	1.05/0.66	Yes	—	1606-XLP60EQT		
100...120/220... 240V AC, 220...375V DC	72	24...28	3	1.60/0.80	Yes	—	1606-XLP72E	
	90	12...15	7.5	1.90/0.90	Yes‡	—	1606-XLP90B	
100...200/200... 240V AC, 220...375V DC	95	24...28	3.9	2.00/0.95	No	—	1606-XLP95E	
	100	24...28	4.2	2.10/1.00	Yes‡	—	1606-XLP100E	
		48...56	2.1	2.10/1.00	Yes‡	—	1606-XLP100F	

Two-Phase

Input Voltage	Output Power [W]	Output Voltage	Output Current [A]	Input Circuit Protection	Steady State Input Current 400...480 [V AC]	Parallel Operation	DC OK Relay	Cat. No.
380...480V AC	90	24...28	3.75	10 A Slow Blow Fuse or Cat. No. 1489-A1C100/ 20 A*	2 x 0.36	No‡	—	1606-XLP90E-2
380...480V AC	100	24...28	4.2		2 x 0.40	Yes‡	—	1606-XLP100E-2

* Unit has internal (not accessible/replaceable) input fuse. Additional protection is not required if used on branch circuits ≤ UL test levels.
‡ Single/parallel operation (inclined characteristic) selectable (jumper). Consult local codes and regulations for installation.

Bulletin 1606 Back-of-Panel Brackets

Instead of snapping the power supply onto a DIN Rail, you can mount it to the back of the panel. This set consists of two steel brackets which replace the existing DIN Rail aluminum brackets at the back of the unit.

Note: You need one set per unit.

Description	Cat. No.
Back-of-panel bracket for XLS and XLE power supplies, below 20 A	1606-XLB
Back-of-panel bracket for XLS and XLE power supplies, 20 A and above	1606-XLC

Raco Mfg. & Engineering Co., Inc
 1400 62nd St
 Emeryville, CA, 94608, US
 Phone: 510-658-6713
 Fax: 510-658-3153
 Toll-free: 800-722-6999
 Email: sales@racoman.com
 Website: http://www.racoman.com

Model Number 301VSS-8C, Verbatim® VSS Autodialer
\$2,350.00

Verbatim® VSS Autodialer

Verbatim® model VSS-8C monitors 8 dry contact inputs plus 120 VAC power source.

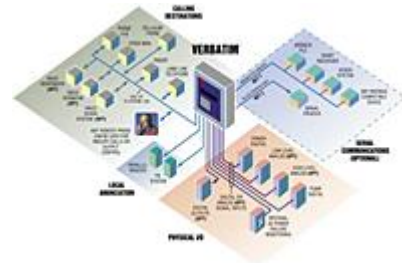

[SPECIFICATIONS](#) · [ELECTRICAL](#) · [PHYSICAL](#) · [ENVIRONMENTAL](#) · [SPEECH MESSAGES](#) · [UL STANDARD](#) · [WARRANTY](#) · [FEATURES](#) · [TELEPHONE](#) · [MODULAR OPTIONS](#) · [FACTORY OPTIONS](#) · [ALARM AUTODIALING](#) · [USER-RECORDED MESSAGES](#) · [A FULLY INTERACTIVE SYSTEM](#) · [SUPERVISORY CONTROL SYSTEM](#) · [SCADA SYSTEM](#) · [PLC NETWORK INTERFACE](#) · [TAKE CONTROL OF REMOTE EQUIPMENT](#) · [MEMORY RETAINED DURING POWER FAILURE](#) · [BATTERY BACKUP FOR SAFETY](#) · [BUILT FOR LONG TERM SURVIVAL IN THE TOUGHEST ENVIRONMENTS](#) · [VIEW PDF OPTIONS](#) · [VIEW PDF SPECIFICATIONS](#) · [VIEW PDF APPLICATION BULLETINS](#)

SPECIFICATIONS

# of Digital Alarm Inputs	8
# of Phone Numbers Dialed	16
Trade Name	Verbatim®
Typical Monitoring Applications	Boilers Chemical Plants Computer Rooms Facility Security Fish Hatcheries Frozen Food Storage

	HVAC Systems Hydroelectric Power Stations Pipeline & Compressor Stations Remote Pump Stations Storage Tanks Telephone Switchgear Unattended SCADA Systems Water & Wastewater Treatment Plants
Typical Sensors	Flow Leak Level Motion pH Power Pressure Temperature Vacuum

ELECTRICAL

Power Requirement	105-135 VAC, 50/60 Hz, 15 watts maximum or 8-14 VDC at 500 mA maximum.
Battery Charging	Precision voltage controlled, including automatic rapid recharge after drain.
Battery Backup Time	20 hours
Input Sensing	Four unpowered contact inputs standard. Open contacts see 5 volts DC; closed contacts see 10 ma DC.
Printer Port	Standard Centronics parallel printer port

PHYSICAL

Surge Protection	Integral gas tube and solid-state protectors on all phone, power, and signal lines. Accommodates field-installed upgrades. Rugged metal indoor enclosure.
Weight	8 lbs 3.6 kg
Height	11 7/8 in.
Width	9 3/4 in.
Depth	5 in.
Mounting Centers	11 3/8" vertical x 6" horizontal

ENVIRONMENTAL

Temperature Range	20 to 130 °F
Humidity	0 to 95%, Non-condensing

SPEECH MESSAGES

Speech Messages	Users record their own messages. Also includes resident vocabulary for programming guidance and for default "alarm/normal" speech if no user messages are recorded.
-----------------	---

UL STANDARD

UL Standard	Verbatim® complies with UL Standards: 1459, 1950.
-------------	---

WARRANTY

Warranty	5 years
----------	---------

FEATURES

- Monitors 4 channels plus internal AC power
- Solid-state message recording
- Expandable modular design
- Superior surge protection on all inputs
- Alarm call grouping
- Low cost
- Remote programming
- Nonvolatile memory
- 20 hour battery backup
- 5 year warranty

TELEPHONE

- Rotary pulse or tone dialing, keyboard selectable.
- Dials up to 16 different numbers, each up to 60 digits long.
- Allows programming of PBX delays in 1 second increments.
- FCC Registered Part 68, "Ringer Equivalence": 0.3A.
- Alarm Acknowledgement is by TouchTone key or by calling back.
- Built-in speaker phone allows two-way conversation.
- Compatible with most cellular telephone systems.

MODULAR OPTIONS

- Channels.** Upgradeable to 8, 16, 24 or 32 contact channels.
- Analog.** Custom scaled in the units of measurement required for your job. Analog alarms on a high and a low alarm setpoint. Upgradeable to 1, 4, 8 or 16 analog channels.
- Remote Supervisory Control.** The operator can turn equipment on or off via any telephone. Upgradeable to 4 or 8 outputs.
- Modbus Interface.** In addition to physical inputs, the unit is upgradeable to 32, 64 or 96 additional alarms of any type via RS232 and Modbus RTU master protocol.
- Cellular Telephone.** Our Cellularm™ System provides temporary or permanent alarm autodialing over the cellular telephone network when conventional telephone lines are disabled or unavailable. Furnished in a rugged, weather-resistant housing that's easy to transport and set up.

FACTORY OPTIONS

- Enclosure.** System available in NEMA 4X enclosure, which is corrosion proof and sealed against 12 feet of water.
- Environmental.** Thermostatically controlled heater available, suggested for operation below 20°F or where condensation may occur.
- Local Alarm Relay Output.** Relay activates during unacknowledged alarm conditions.
- Secure Front Panel.** Verbatim® System furnished without front panel programming controls and indicators. Restricts access to unsupervised or remotely located units, as well as reducing the initial purchase price.
- Solar Electric Generator Systems.** Ideal for remote location applications where conventional power and telephone services are not available or too costly. Provides steady, clean power and has sufficient storage capacity for overcast and inclement weather conditions.

ALARM AUTODIALING

Interposing/Isolation Relays

Overview/Product Selection

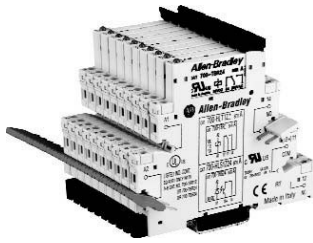

Bulletin 700-HL “Terminal Block Relay”

- Relay and Socket Assembled Interface Modules For High Density Interposing or Isolation Applications
- Screw Terminal and Spring Clamp Bases
- 6 A Relay, Choice of Silver or Gold Contacts
- 2 A Solid-State Relay
- SPDT (Relay), 1 N.O. (Solid-State)
- Built-in Retainer Clip and Snap-in Marker Lever
- Standard LED, Reverse Polarity Protection, and Surge Protection
- Externally Replaceable Relay Modules
- Unique Leakage Current Suppression Version to Address Industry Concerns of Nuisance Coil Turn-on or Contact Non-Drop Out when Connecting to PLCs with Leakage Current

Table of Contents





- Product Selection ... this page
- Accessories 9-51
- Specifications 9-52
- Approximate Dimensions 9-54
- Standards Compliance and Certifications**
- See Specification Table In This Section.

Product Selection

Standard built-in Features:				
	<ul style="list-style-type: none"> • LED • Reverse Polarity Protection for DC Inputs • Coil Surge Protection 			
Specifications				
Output Type	SPDT (1 C/O); $I_{th} = 6A\ddagger$		1 N.O. solid-state; $I_{th} = 2 A, 24V DC$	
Recommended Tightening Torque	0.5 Nm max. (4.4 lb.-in.)			
Wire Range	Screw Terminal: 0.14 mm ² ...2.5 mm ² (#26...#14 AWG), Spring Terminal: 0.2 mm ² ...2.5 mm ² (#24...#14 AWG)			
Approvals	cULus, cURus, ABS, CE			

Assembled Devices	Pkg. Quantity	Cat. No. (Screw Terminals)	Cat. No. (Spring Clamp Terminals)	Pkg. Quantity	Cat. No. (Screw Terminals)	Cat. No. (Spring Clamp Terminals)
Input Voltage						
12V DC	10	700-HLT1Z12†	700-HLT2Z12	—	—	—
24V DC	10	700-HLT1Z24†	700-HLT2Z24	10	700-HLS1Z24†	700-HLS2Z24
48V DC	10	700-HLT1Z48†	700-HLT2Z48	10	700-HLS1Z48†	700-HLS2Z48
12V AC/DC	10	700-HLT1U12	700-HLT2U12	—	—	—
24V AC/DC	10	700-HLT1U24	700-HLT2U24	—	—	—
48V AC/DC	10	700-HLT1U48	700-HLT2U48	—	—	—
110/125V AC/DC	10	700-HLT1U1	700-HLT2U1	10	700-HLS1U1†	700-HLS2U1
220...240V AC/DC	10	700-HLT1U2	700-HLT2U2	10	700-HLS1U2†	700-HLS2U2
Built-in LCSC (leakage current suppression circuit) 120V AC and 125V DC§	10	700-HLT1L1†	—	10	700-HLS1L1†	—
Built-in LCSC (leakage current suppression circuit) 240V AC§	10	700-HLT1L2†	—	10	700-HLS1L2†	—

* Reverse polarity on the output terminals of the solid-state relay will result in the output being “On” regardless of the state of the input voltage.
 † Electromechanical relay to solid-state relay interchangeability is possible.
 ‡ For Gold-plated contacts: Add the letter “X” at the end of the catalog number. For example: if Cat. No. 700-HLT1Z24 is required with gold plating, the new cat. no. is 700-HLT1Z24X.
 § Leakage current suppression up to 2.2 mA off state current.

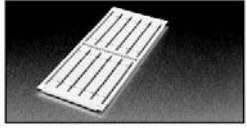
	Description	Pkg. Quantity	Socket Input Voltage	Cat. No.
 Cat. No. 700-TBR24	Replacement Relays Order must be for 20 relays or multiples of 20.	20	12V	700-TBR12*
			24V	700-TBR24*
			48V	700-TBR48*
			110/125V 220...240V 120V...125V 240V	700-TBR60*
 Cat. No. 700-TBS24	Replacement SSR 4-blade miniature relay for use with 1 N.O. SSR output. Order must be for 20 relays or multiples of 20.	20	24V	700-TBS24
			48V 110/125V 220...240V 120V...125V 240V 120/125V	700-TBS60
 Cat. No. 700-TBJ20B	20-Way Jumper Can be cut to required length. <i>I</i> _{th} =36 A max per 20-way jumper.	1	Color	
			Red	700-TBJ20R
			Gray	700-TBJ20G
			Blue	700-TBJ20B
 Cat. No. 700HN177	End Barrier Used for visual inspection of groups, safe separation of neighboring 700-HL modules that end with jumpers. Order must be for 10 or multiples of 10.	10	Black	700-HN177
	Snap-in Marker These snap-in markers have a 6 x 10 mm surface and snap into the ejection lever for the relay.	100	Blank	1492-MC6X10
			Standard 1492-MC6X10	www.ab.com/catalogs for information
			Custom	†

* For gold-plated contacts: Add the letter "X" at the end of the catalog number. For example: if Cat. No. 700-TBR24 is required with gold plating, the new cat. no. is 700-TBR24X. Also add \$1 (US) to the price per relay.

† Go to <http://www.ab.com/software/termblock/index.html> and download software. Create custom text, save file, and e-mail to your local Allen-Bradley distributor.

Note: Terminal block relay bases are not sold separately.

Bulletin 700-HL
Interposing/Isolation Relays
Specifications*

Cat. No. 700-HLT... (Relay Output)							
Electrical Ratings							
Pilot Duty Rating	6 A NEMA B 300, R 300						
Rated Thermal Current (I_{th})	1-Pole — 6 A						
Rated Insulation Voltage (U_i)	250V IEC, 300V UL/CSA						
Contacts	Inductive	1-Pole					
	24V AC, 1-phase	30 A	▶][◀	5 A	◀][▶		
	120V AC, 1-phase	30 A		3 A			
	240V AC, 1-phase	15 A		1.5 A			
	Make, Break & Continuous V DC	24V DC					1.0 A
120V DC					0.2 A		
240V DC					0.1 A		
Min. Permissible Contact Ratings	12V, 6 mA (72 mW) for Silver Contacts, 8V, 2.5 mA (20 mW) for Gold Contacts						
Permissible Coil Voltage Variation	Pickup:	85...110% of Nominal Voltage at 50 Hz 85...110% of Nominal Voltage at 60 Hz 80...110% of Nominal Voltage at DC				Must Dropout Voltage:	10% of Nominal Voltage at AC 5% of Nominal Voltage at DC
Power Consumption ±10%	AC	0.3 VA					
	DC	0.2 W					
Design Specification/Test Requirements							
Dielectric Withstand Voltage	Pole to Pole (VRMS)	1000V					
	Contact to Coil (VRMS)	4000V					
Input Voltage	12V AC/DC	24V AC/DC	48V AC/DC	120V AC/DC	240V AC/DC	120V LCSC	240V LCSC
Impedance (Ohms)	1 K	2 K	6 K	26 K	56 K	16 K	35 K
Mechanical							
Degree of Protection	IP20						
Mechanical Life Operations	1 x 10 ⁷						
Electrical Life Operations	6 A Resistive: 100,000 min. 24V DC, 1 A Inductive: 200,000 min. 120V AC 1 A Inductive: 300,000 min.						
Switching Frequency Operations (no-load)	10 cycles/sec						
Coil Voltages	See Overview/Product Selection						
Operating Time at Nominal Voltage at 20°C (ms)	Pickup	7 ms					
	Dropout	3 ms					
Maximum Operating Rate (full load = 6 A)	6 cycles/min.						
Coil Surge Protection	Per EN 61000-4-5; Surge Immunity (801-5) Class III: 2 kV common and 1 kV differential mode						
Environmental							
Temperature	Operating	-40...+55 °C					
	Storage	-40...100 °C					
Altitude	2000 m (6560 ft)						
Construction							
Insulating Material	Molded High Dielectric Material						
Enclosure	Relay IP67						
Contact Material	Silver Tin Ox., AgSnO or Silver with Gold Plating, AgSnO + Au						
Terminal Markings on Socket	In accordance with EN50 0005						
Certifications	cURus Recognized, File E3125, Guide NLDX 2, cULus Listed, with Allen-Bradley socket, CE Marked (per EU Low Voltage Directive 73/23 EEC 93/68 EEC), ABS (American Bureau of Shipping)						
Standards	EN60947-4-1, EN60947-5-1, IEC 947CSA 22.2, UL 508, NEMA IEE MAC Compliant, ICS-2 Compliant						

* Performance Data – See Important 2, publication A115.

1769-L3x Local I/O Performance

There is one requested packet interval (RPI) for the entire 1769 backplane (1...750 ms). As you install modules, the minimum backplane RPI increases. The RPI defines the frequency at which the controller sends and receives all I/O data on the backplane.

Type of Module	Considerations
Digital and analog (any mix)	<ul style="list-style-type: none"> 1...4 modules can be scanned in 1 ms 5...30 modules can be scanned in 2 ms Some input modules have a fixed 8 ms filter, so selecting a faster RPI has no effect
Specialty	<ul style="list-style-type: none"> Full-sized 1769-SDN modules add 2 ms per module 1769-HSC modules add 1 ms per module Full-sized 1769-ASCII modules add 1 ms per module

You can always select an RPI that is slower than listed above. These considerations show how fast modules can be scanned—not how fast an application can use the data. The RPI is asynchronous to the program scan. Other factors, such as program execution duration, affect I/O throughput.

Technical Specifications - 1769 Standard CompactLogix Controllers

Attribute	1769-L31	1769-L32C	1769-L32E	1769-L35CR	1769-L35E
User memory	512 KB	750 KB	750 KB	1.5 MB	1.5 MB
Optional flash memory	1784-CF64 1784-CF128				
Number of I/O modules, max	16	16	16	30	30
Number of I/O banks, max	3				
Number of expansion I/O modules, max	16 1769 modules			30 1769 modules	
Replacement battery	1769-BA				
Current draw @ 5V DC	330 mA	650 mA	660 mA	680 mA	660 mA
Current draw @ 24V DC	40 mA	40 mA	90 mA	40 mA	90 mA
Power dissipation	2.61 W	4.21 W	5.5 W	4.36 W	5.5 W
Isolation voltage	30V (continuous), basic insulation type Type tested at 710V DC for 60 s; RS232 channel 0 to system No isolation between RS232 channel 1 and system	30V (continuous), basic insulation type Type tested at 710V DC for 60 s; RS232 to system, ControlNet to system, RS232 to ControlNet, ControlNet channel A to ControlNet channel B	30V (continuous), basic insulation type Type tested at 710V DC for 60 s; RS232 to system, Ethernet to system, RS232 to Ethernet	30V (continuous), basic insulation type Type tested at 710V DC for 60 s; RS232 to system, ControlNet to system, RS232 to ControlNet, ControlNet channel A to ControlNet channel B	30V (continuous), basic insulation type Type tested at 710V DC for 60 s; RS232 to system, Ethernet to system, RS232 to Ethernet

Technical Specifications - 1769 Standard CompactLogix Controllers

Attribute	1769-L31	1769-L32C	1769-L32E	1769-L35CR	1769-L35E
Communication ports	CH0 - RS-232 DF1, DH-485, ASCII Fully isolated 38.4 Kbps max CH1 - RS-232 DF1, DH-485 Nonisolated 38.4 Kbps max	RS232 Fully isolated 38.4 Kbps max ControlNet port	RS232 Fully isolated 38.4 Kbps max EtherNet/IP port 10/100 BASE-T	RS232 Fully isolated 38.4 Kbps max ControlNet port	RS232 Fully isolated 38.4 Kbps max EtherNet/IP port 10/100 BASE-T
Serial cables	1756-CP3 or 1747-CP3, right angle connector to controller, straight to serial port, 3 m				
Weight, approx.	0.30 kg (0.66 lb)	0.32 kg (0.70 lb)	0.30 kg (0.66 lb)	0.32 kg (0.70 lb)	0.30 kg (0.66 lb)
Slot width	1				
Module location	DIN rail or panel mount				
Panel-mounting screw torque	1.1...1.8 N•m (10...16 lb•in) - use M4 or #8 screws				
Power supply distance rating	4 modules				
Power supply	1769-PA2, 1769-PB2, 1769-PA4, 1769-PB4				
Wire category ⁽¹⁾	2 - on communication ports				
North American temperature code	T5	T4A			
Enclosure type rating	None (open-style)				

⁽¹⁾ Use this conductor category information for planning conductor routing as described in the system level installation manual. See the Industrial Automation Wiring and Grounding Guidelines, publication [1770-4.1](#).

Certifications - 1769 Standard CompactLogix Controllers

Certification ⁽¹⁾	1769-L31	1769-L32C, 1769-L35CR	1769-L32E, 1769-L35E
c-UL-us	UL Listed Industrial Control Equipment, certified for US and Canada. See UL File E65584. UL Listed for Class I, Division 2 Group A,B,C,D Hazardous Locations, certified for U.S. and Canada. See UL File E194810.		
CE	European Union 89/336/EEC EMC Directive, compliant with: <ul style="list-style-type: none"> • EN 61326-1; Meas./Control/Lab., Industrial Requirements • EN 61000-6-2; Industrial Immunity • EN 61000-6-4; Industrial Emissions • EN 61131-2; Programmable Controllers (Clause 8, Zone A & B) 		European Union 89/336/EEC EMC Directive, compliant with: <ul style="list-style-type: none"> • EN 61000-6-2; Industrial Immunity • EN 61000-6-4; Industrial Emissions
C-Tick	Australian Radiocommunications Act, compliant with: AS/NZS CISPR 11; Industrial Emissions		
ATEX	—		European Union 94/9/EC ATEX Directive, compliant with: <ul style="list-style-type: none"> • EN 60079-15; Potentially Explosive Atmospheres, Protection "n" (II 3 G Ex nA IIC T4 X) • EN 60079-0; General Requirements (Zone 2)
CI	—	ControlNet International conformance tested to ControlNet specifications	—
EtherNet/IP	—	—	ODVA conformance tested to EtherNet/IP specifications.

⁽¹⁾ When marked. See the Product Certification link at <http://www.ab.com> for Declarations of Conformity, Certificates, and other certification details.

Step 4 - Select:

- *if power consumption exceeds the maximum for a single power supply, install additional banks and power supplies*

Selecting Power Supplies

Compact I/O power supplies distribute power from either side of the power supply. For example, a 2A at 5V dc power supply (1769-PA2, -PB2) can provide 1A to the right side of the power supply and 1A to the left. A 4A at 5V dc power supply (1769-PA4, -PB4) can provide 2A to the right side of the power supply and 2A to the left.

Specification	1769-PA2	1769-PB2	1769-PA4	1769-PB4
Nominal Input Voltage	120V ac or 240V ac	24V dc	120V ac or 240V ac	24V dc
Input Voltage Range	85...265V ac	19.2...31.2V dc	85...265V ac	19.2...32V dc
Maximum Line Requirement	100VA @ 120V ac 130VA @ 240V ac	50VA @ 24V dc	200VA @ 120V ac 240VA @ 240V ac	100VA @ 24V dc
Output Bus Current Capacity (0° to 55°C)	2 A @ 5V dc 0.8 A @ 24V dc		4 A @ 5V dc 2 A @ 24V dc	
24V dc User Power Capacity (0° to 55°C)	250 mA	na	na	na
Maximum Inrush	25A at 132V ac, 10Ω source impedance 40A at 265V ac, 10Ω source impedance	30A at 31.2V dc	25A at 132V ac, 10Ω source impedance 40A at 265V ac, 10Ω source impedance	30A at 31.2V dc
Line Loss Ride Through	10 ms (minimum) to 10s (maximum)		5 ms (minimum) to 10s (maximum)	
Minimum Load Current	0 mA at 5V dc; 0 mA at 24V dc			
Short Circuit Protection	Front Access Fuse (replacement part number: Wickmann 19195-3.15A, Wickmann 19343-1.6A, or Wickmann 19181-4A)	Front Access Fuse (replacement part number: Wickmann 19193-6.3A)	Front Access Fuse (replacement part number: Wickmann 19195-3.15A or Wickmann 19181-4A)	Front Access Fuse (replacement part number: Wickmann 19193-6.3A)
Bus Overvoltage Protection	for both +5V dc and for +24V dc			
Isolation Voltage (input power to 1769 bus) Verified by one of these dielectric tests	1836V ac for 1s or 2596V dc for 1s or 265V Working Voltage (IEC Class 1 - grounding required)	1200V ac for 1s or 1697V dc for 1s or 75V Working Voltage (IEC Class 1 - grounding required)	1836V ac for 1s or 2596V dc for 1s or 265V Working Voltage (IEC Class 1 - grounding required)	1200V ac for 1s or 1697V dc for 1s or 75V Working Voltage (IEC Class 1 - grounding required)
Power Supply Distance Rating	8 (up to eight I/O modules can be connected on either side of the power supply for a maximum of 16 modules)			

Certifications: UL 508, CSA (Class I, Division 2, Group A, B, C, D), CE

Adding end caps

The controller is the leftmost module in the CompactLogix system. The controller has built-in termination, so the leftmost end of the system is terminated.

The final I/O bank in the CompactLogix system needs an end cap on the end without the expansion cable.

For a:	Order:
right end cap	1769-ECR
left end cap	1769-ECL

Selecting local or remote (distributed) I/O

In addition to local I/O, the CompactLogix controller can control remote (distributed) I/O via:

- EtherNet/IP using a 1769-L32E or 1769-L35E controller
- DeviceNet using a 1769-SDN scanner module

While local I/O can be lower cost and easier to configure, configuring remote I/O offers:

- more versatility in laying out your system
- more communication options, such as DeviceNet and EtherNet/IP
- ability to configure the listen only communication format for remote I/O modules

1769 Compact Digital ac Input Modules

Cat. No.	Number of Inputs	Voltage Category/Type, Input	Voltage Range	Input Delay Time, ON to OFF	Current, On-State Input, Min.	Current, Off-State Input, Max.	Backplane Current (mA) at 5V	Power Supply Distance Rating
1769-IA8I	8 individually isolated	100 or 120V ac	79...132V ac @ 47...63Hz	20 ms	5 mA @ 79V ac	2.5 mA	90 mA	8 modules
1769-IA16	16	100 or 120V ac	79...132V ac @ 47...63Hz	20 ms	5 mA @ 79V ac	2.5 mA	115 mA	8 modules
1769-IM12	12	200 or 240V ac	159...265V ac @ 47...60Hz	20 ms	5 mA @ 159V ac	2.5 mA	100 mA	8 modules

1769 Compact Digital ac Output Modules

Cat. No.	Number of Outputs	Voltage Category/Type, Output	Voltage Range	Leakage Current, Off-State Output, Max	Current per Output, Max.	Current per Module, Max.	Backplane Current (mA) at 5V	Power Supply Distance Rating
1769-OA8	8	100...240V AC	85...265 ac @ 47...63Hz	2.0 mA at 132V ac* 2.5 mA at 265V ac	0.25 A @ 60 °C (140 °F) 0.50 A @ 30 °C (86 °F)	2.0 A @ 60 °C (140 °F) 4.0 A @ 30 °C (86 °F)	145 mA	8 modules
1769-OA16	16	100...240V AC	85...265 ac @ 47...63Hz	2.0 mA at 132V ac* 2.5 mA at 265V ac	0.25 A @ 60 °C (140 °F) 0.50 A @ 30 °C (86 °F)	4.0 A @ 60 °C (140 °F) 8.0 A @ 30 °C (86 °F)	225 mA	8 modules

*Recommended Loading Resistor - To limit the effects of leakage current through solid state outputs, a loading resistor can be connected in parallel with your load. For 120V ac operation, use a 15 k Ω , 2W resistor. For 240V ac operation use a 15 k Ω , 5W resistor.

1769 Compact Digital dc Input Modules

Cat. No.	Number of Inputs	Voltage Category/Type, Input	Voltage Range	Input Delay Time, ON to OFF	Current, On-State Input, Min.	Current, Off-State Input, Max.	Backplane Current (mA) at 5V	Power Supply Distance Rating
1769-IG16	16	5V dc, TTL input	4.5...5.5V dc	0.5 ms	1.5 mA off-state*	0.6 mA on-state*	120 mA	8 modules
1769-IQ6XOW4	6	24V dc, sinking or sourcing	10...30V dc @ 30 °C (86 °F) 10...26.4V dc @ 60 °C (140 °F)	8 ms	2 mA	1.5 mA	105 mA	8 modules
1769-IQ16	16	24V dc, sinking or sourcing	10...30V dc @ 30 °C (86 °F) 10...26.4V dc @ 60 °C (140 °F)	8 ms	2 mA	1.5 mA	115 mA	8 modules
1769-IQ16F	16 high-speed	24V dc, sinking or sourcing	10...30V dc @ 30 °C (86 °F) 10...26.4V dc @ 60 °C (140 °F)	1 ms	2 mA	1.5 mA	110 mA	8 modules
1769-IQ32	32	24V dc, sinking or sourcing	10...30V dc @ 30 °C (86 °F) 10...26.4V dc @ 60 °C (140 °F)	8 ms	2 mA	1.5 mA	170 mA	8 modules
1769-IQ32T	32 terminated	24V dc, sinking or sourcing	20.4...26.4V dc	8 ms	3 mA	1.7 mA	170 mA	8 modules

TTL inputs are inverted (0.2...0.8V dc = logic low voltage = ON-state; 2.0...5.5V dc = logic high voltage = OFF-state).

1769 Compact Digital dc Output Modules

Cat. No.	Number of Outputs	Voltage Category/Type, Output	Voltage Range	Leakage Current, Off-State Output, Max	Current per Output, Max.	Current per Module, Max.	Backplane Current (mA) at 5V	Power Supply Distance Rating
1769-OB8	8	24V dc, sourcing	20.4...26.4V dc	1.0 mA @ 26.4V dc	2.0 A @ 60 °C (140 °F)	8.0 A @ 60 °C (140 °F)	145 mA	8 modules
1769-OB16	16	24V dc, sourcing	20.4...26.4V dc	1.0 mA @ 26.4V dc	0.5 A @ 60 °C (140 °F) 1.0 A @ 30 °C (86 °F)	4.0 A @ 60 °C (140 °F) 8.0 A @ 30 °C (86 °F)	200 mA	8 modules
1769-OB16P	16 protected	24V dc, sourcing	20.4...26.4V dc	1.0 mA @ 26.4V dc	0.5 A @ 60 °C (140 °F) 1.0 A @ 30 °C (86 °F)	4.0 A @ 60 °C (140 °F) 8.0 A @ 30 °C (86 °F)	160 mA*	8 modules
1769-OB32	32	24V dc, sourcing	20.4...26.4V dc	1.0 mA @ 26.4V dc	0.5 A @ 60 °C (140 °F) 1.0 A @ 30 °C (86 °F)	8.0 A @ 60 °C (140 °F) 16.0 A @ 30 °C (86 °F)	300 mA	6 modules
1769-OB32T	32 terminated	24V dc, sourcing	10.2...26.4V dc	0.1 mA @ 26.4V dc	0.5 A @ 60 °C (140 °F) 1.0 A @ 30 °C (86 °F)	4.0 A @ 60 °C (140 °F) 8.0 A @ 30 °C (86 °F)	220 mA	8 modules
1769-OG16	16	5V dc, TTL output	4.5...5.5V dc	—	0.24 A @ 60 °C (140 °F)	0.38 A @ 60 °C (140 °F)	200 mA	8 modules
1769-OV16	16	24V DC, sinking	20.4...26.4V dc	1.0 mA @ 26.4V dc	0.5 A @ 60 °C (140 °F) 1.0 A @ 30 °C (86 °F)	4.0 A @ 60 °C (140 °F) 8.0 A @ 30 °C (86 °F)	200 mA	8 modules
1769-OV32T	32 terminated	24V dc, sinking	10.2...26.4V dc	1.0 mA @ 26.4V dc	0.5 A @ 60 °C (140 °F) 1.0 A @ 30 °C (86 °F)	4.0 A @ 60 °C (140 °F) 8.0 A @ 30 °C (86 °F)	220 mA	8 modules

1769 Compact Digital Contact Output Modules

Cat. No.	Number of Outputs	Voltage Category/Type, Output	Voltage Range	Leakage Current, Off-State Output, Max	Current per Output, Max.	Current per Module, Max.	Backplane Current (mA) at 5V	Backplane Current (mA) at 24V	Power Supply Distance Rating
1769-IQ6XOW4	4	24V dc	5...265V ac 5...125V dc	0 mA	2.5 A	8.0 A	105 mA	50 mA	8 modules
1769-OW8	8	24V dc	5...265V ac 5...125V dc	0 mA	0.5 A @ 60 °C (140 °F) 1.0 A @ 30 °C (86 °F)	16 A	125 mA	100 mA	8 modules
1769-OW8I	8 individually isolated	24V dc	5...265V ac 5...125V dc	0 mA	0.5 A @ 60 °C (140 °F) 1.0 A @ 30 °C (86 °F)	16 A	125 mA	100 mA	8 modules
1769-OW16	16	24V dc	5...265V ac 5...125V dc	0 mA	2.5 A	20 A	205 mA	180 mA	8 modules

Relay Contact Ratings

These ratings apply to the digital contact output modules.

Volts, Max.	Continuous Amps per Point	Amperes		Voltamperes		IEC 947	NEMA ICS 2-125
		Make	Break	Make	Break		
240V ac	2.5 A	7.5 A	0.75 A	1800 VA	180 VA	AC15*	C300
120V ac		15 A	1.5 A				
125V dc	1.0 A	0.22 A		28 VA		DC13*	R150
24V dc	2.0 A	1.2 A		28 VA		—	—

*Does not apply to the 1769-OW16 module.

Analog I/O Modules

Choose from a wide variety of analog, thermocouple, and RTS modules. Features include:

- Individually configurable channels
- On-board scaling
- Autocalibration of inputs
- Selectable input filters
- Over-range and under-range detection and indication
- Input modules offer both single-ended or differential inputs
- High accuracy rating

1769 Compact Analog Modules

Cat. No.	Number of Inputs	Number of Outputs	Resolution, Bits	Signal Range	Sensors Supported	Backplane Current (mA) at 5V	Backplane Current (mA) at 24V	Power Supply Distance Rating
1769-IF4	4	—	14 bits (unipolar)	0...20 mA 4...20 mA 0...10V dc ±10V dc 0...5V dc 1...5V dc	—	105 mA	60 mA	8 modules
1769-IF4I	4 individually isolated	—	16 bits (unipolar)	±10.5V dc -0.5...10.5V dc -0.5...5.25V dc 0.5...5.25V dc	—	145 mA	95 mA	8 modules
1769-IF8	8	—	16 bits (unipolar)	0...20 mA 4...20 mA 0...10V dc ±10V dc 0...5V dc 1...5V dc	—	120 mA	70 mA	8 modules
1769-OF2	—	2	14 bits	—	—	120 mA	120 mA*	8 modules
1769-OF4CI	—	4 current, individually isolated	16 bits (unipolar)	4...20 mA 0...20V mA	—	145 mA	140 mA	8 modules
1769-OF4VI	—	4 voltage, individually isolated	16 bits (unipolar)	-10...10V dc 0...5V dc 0...10V dc 1...5V dc	—	145 mA	75 mA	8 modules
1769-OF8C	—	8 current	16 bits (unipolar)	0...20 mA 4...20 mA	—	145 mA	160 mA	8 modules
1769-OF8V	—	8 voltage	16 bits (unipolar)	±10.5V dc -0.5...10.5V dc -0.5...5.25V dc 0.5...5.25V dc	—	145 mA	125 mA	8 modules
1769-IF4XOF2	4	2 individually isolated	8 bits plus sign* individually isolated	0...10V dc ±10V dc 0...5V dc 1...5V dc	—	120 mA	160 mA	8 modules
1769-IR6	6	—	Input filter and configuration dependent	—	100, 200, 500, 1000 Ω Platinum, alpha=385 100, 200, 500, 1000 Ω Platinum, alpha=3916 120 Ω Nickel, alpha=672 120 Ω Nickel, alpha=618 10 Ω Copper 604 Ω Nickel-Iron 518 0...150 Ω 0...500 Ω 0...1000 Ω 0...3000 Ω	100 mA	45 mA	8 modules
1769-IT6	6, plus 2 cold junction sensors	—	—	—	Thermocouple types: J, K, T, E, R, S, B, N, C ±50mV ±100mV	100 mA	40 mA	8 modules

*If the optional 24V dc Class 2 power supply is used, the 24V dc current draw from the bus is 0 mA.

*Sign is always positive.



■ AC Power/Industrial Products

DRS Series Data/Signal Din Rail

The **DRS Series** is a din-rail mountable, single-pair surge suppression module implementing three-stage hybrid technology. This module addresses overvoltage transients with gas tubes and silicon avalanche components. In addition, sneak currents are mitigated with resettable fuses (PTCs). The PTCs increase resistance several orders of magnitude when overcurrents exceed safe levels. A normal state resumes when overcurrents are removed. The ability to self-restore in this manner significantly increases suppressor performance and survivability.

The **DRS Series** mounts onto a standard 35mm industrial din rail. There are three "Field Side" and three "Electronics Side" screw terminals. One is reserved for a shield. Three electrically tied ground terminals are provided for grounding the DRS Series unit to Building Approved Ground. Shield is isolated from ground. For a 2-terminal version without a shield order the DRS-xxx-2.

Keeping
You
Connected!



NEED HELP? Call 1-800-648-4076

1805 N.E. 19th Avenue
P.O. Box 1778
Ocala, Florida 34478

(352) 732-3029
FAX (352) 867-1237

Sales: 1-800-648-4076

E-mail us at:
edco@edcosurge.com

Internet:
<http://www.edcosurge.com>



FEATURES

- Low-Voltage Data Surge Protection
- Three-Stage Hybrid Protection
- Sneak/Fault Current Protection With Resettable Fuses (PTCs)
- Low-Profile Packaging
- Easy Installation
- Fits Standard 35mm Din Rail
- Fast Response Time <1 Nanosecond
- UL 497B Listed



AC Power/Industrial Products



DRS Series Data/Signal Din Rail

SPECIFICATIONS							
Part #	Max Peak Signal Voltage	Nominal Breakdown Voltage	Max Current I _p 10X1000μs (Occurrences)	Peak Current 8x20μs	Typ Cap (pf)	Max Continuous Current	Nominal Series Resistance
DRS-008	6	8	>100	10KA	1500	150ma	5 Ohms
DRS-015	12	15	>100	10KA	1500	150ma	5 Ohms
DRS-232	15	22	>100	10KA	1500	150ma	5 Ohms
DRS-030	24	30	>100	10KA	1500	150ma	5 Ohms
DRS-036	30	36	>100	10KA	1500	150ma	5 Ohms
DRS-043	35	43	>100	10KA	1500	150ma	5 Ohms
DRS-050	43	50	>100	10KA	1500	150ma	5 Ohms
DRS-060	52	60	>100	10KA	1500	150ma	5 Ohms
DRS-175	200	250	>10	8KA	1500	150ma	5 Ohms
** DRS-130 RMS	170	200	>10	8KA	1500	5000	None

**** WARNING!!** For Discrete Signal Use Only. Do not use **DRS-130RMS** on 120 VAC Power Lines. This unit is a Non-Hybrid, MOV design, rated above 5A operational current and can withstand greater than eight occurrences of a 10KA 8x20μs waveform, and greater than 1000 occurrences of a 200A 10x1000μs waveform.

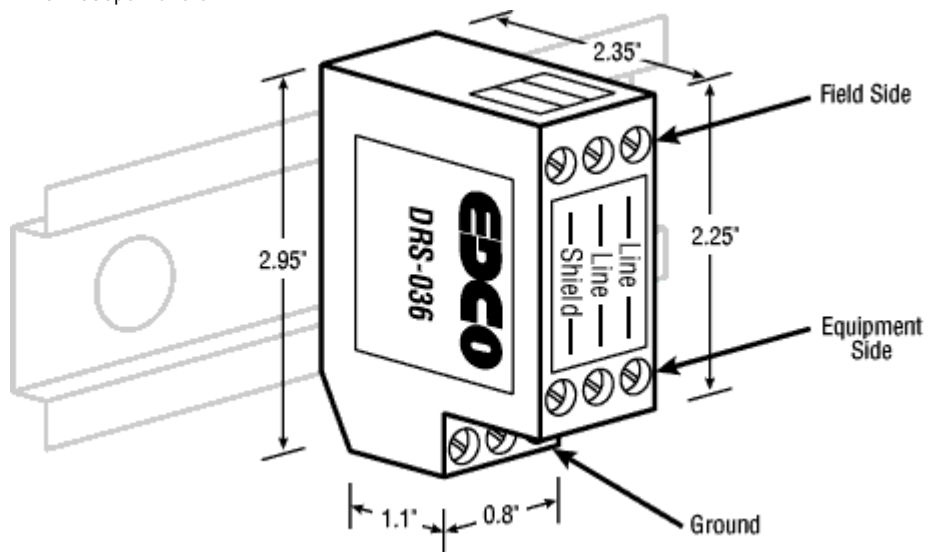

Keeping
You
Connected!



NEED HELP?
Call 1-800-648-4076

1805 N.E. 19th Avenue
P.O. Box 1778
Ocala, Florida 34478

(352) 732-3029
FAX (352) 867-1237

Sales: 1-800-648-4076

E-mail us at:
edco@edcosurge.com

Internet:
<http://www.edcosurge.com>





SPIDER 8TX

Industrial Networking:Industrial Ethernet:Rail Family:Unmanaged Rail-Switches

Product description	
Description	Entry Level Industrial ETHERNET Rail Switch, store and forward switching mode, Ethernet (10 Mbit/s) and Fast-Ethernet (100 Mbit/s)
Port type and quantity	8 x 10/100BASE-TX, TP cable, RJ45 sockets, auto-crossing, auto-negotiation, auto-polarity
Type	SPIDER 8TX
Order No.	943 376-001
More Interfaces	
Power supply/signaling contact	1 plug-in terminal block, 3-pin / no signal contact
Network size - length of cable	
Twisted pair (TP)	0 - 100 m
Network size - cascability	
Line - / star topology	Any
Power requirements	
Operating voltage	9,6 V DC - 32 V DC
Current consumption at 24 V DC	Max. 160 mA
Power consumption	Max. 3,9 W 13,3 Btu (IT)/h at 24 V DC
Service	
Diagnostics	LEDs (power, link status, data, data rate)
Ambient conditions	
Operating temperature	0 °C to +60 °C
Storage/transport temperature	-40 °C to +70 °C
Relative humidity (non-condensing)	10% to 95%
MTBF	105.7 years; MIL-HDBK 217F: Gb 25 °C
Mechanical construction	
Dimensions (W x H x D)	40 mm x 114 mm x 79 mm
Mounting	DIN Rail 35 mm
Weight	177 g
Protection class	IP 30
Mechanical stability	
IEC 60068-2-27 shock	15 g, 11 ms duration, 18 shocks
IEC 60068-2-6 vibration	3.5 mm, 3 Hz - 9 Hz, 10 cycles, 1 octave/min.; 1g, 9 Hz - 150 Hz, 10 cycles, 1 octave/min.
EMC interference immunity	
EN 61000-4-2 electrostatic discharge (ESD)	6 kV contact discharge, 8 kV air discharge
EN 61000-4-3 electromagnetic field	10 V/m (80 - 1000 MHz)
EN 61000-4-4 fast transients (burst)	2 kV power line, 4 kV data line
EN 61000-4-5 surge voltage	Power line: 2 kV (line/earth), 1 kV (line/line), 1 kV data line
EN 61000-4-6 conducted immunity	10 V (150 kHz - 80 kHz)
EMC emitted immunity	
FCC CFR47 Part 15	FCC CFR47 Part 15 Class A
EN 55022	EN 55022 Class A
Approvals	
Safety of industrial control equipment	cUL 508 (E175531)
Scope of delivery and accessories	
Scope of delivery	Device, terminal block, operating manual



Cat6 Patch Cords

Quiktron's Cat6 Patch Cords deliver uncompromising performance and exceptional value. Each cable meets or exceeds Cat6 TIA/EIA- 568-B-2.1 standards and are designed to handle bandwidth intensive applications. The pairs in these cables feature a high tolerance twist design that helps maintain the twist spacing up to the termination point. This drastically reduces both impedance and structural return loss (SRL) as compared to standard Cat5E wire and keeps Near-end Crosstalk (NEXT) levels to a minimum.

Features:

- Connector: 50-micron gold plated RJ-45 Male to Male
- Conductor: 24 AWG Stranded Copper
- Meets or exceeds all Cat6 TIA/EIA- 568-B-2.1
- Q-Series Cat6 Patch Cords are made in the U.S.A.
- Available in custom lengths and colors
- Both Q-Series and Value Series Cat6 Patch Cords feature a lifetime warranty
- Contact your local distributor or Quiktron representative for a complete list of options



Cat5E vs Cat6 Cable

With the rapid growth streaming video, audio, and other multimedia, there is a growing need for increased bandwidth. It's like cars and traffic congestion. When new roads are built they are typically suitable for the amount of travel that passes over them. But as human and car populations grow, roads that were once sufficient become congested and everyone's progress is slowed. Adding more lanes, or in the case of computer networking adding more bandwidth, is the most practical solution to the problem.

Cat6 cable does just that - it provides more bandwidth compared to Cat5E cable. EIA/TIA specification for Cat6 is 250MHz compared to 100MHz for Cat5E. In addition to providing more bandwidth, Cat6 features better near-end crosstalk return loss, equal level far end crosstalk, and insertion loss compared to Cat5E. In a nutshell, Cat6 offers a bigger pipe through which data can travel and has higher immunity to noise, which can interrupt data flow.

All Quiktron Cat6 patch cords meet or exceed Category 6 TIA/EIA 568-B-2.1 specifications, and are constructed from quality components that provide a lifetime of hassle-free connectivity. For absolute best performance, choose Quiktron's Certified Cat6 Patch Cords, which are individually tested to ensure the highest performance possible.

Cat5E vs Cat6 Cable

	Category 5E	Category 6
Frequency	100 MHz	250 MHz
Attenuation (Min. at 100 MHz)	22 dB	19.8 dB
Characteristic Impedance	100 Ohms ± 15%	100 Ohms ± 15%
NEXT (Min. at 100 MHz)	35.3 dB	44.3 dB
PS-NEXT (Min. at 100 MHz)	32.3 dB	42.3 dB
ELFEXT (Min. at 100 MHz)	23.8 dB	27.8 dB
PS-ELFEXT (Min. at 100 MHz)	20.8 dB	24.8 dB
Return Loss (Min. at 100 MHz)	20.1 dB	20.1 dB
Delay Skew (Max. per 100 m)	45 ns	45 ns



Q-Series Cat6 Patch Cords

	Black	Blue	Gray	Green	Orange	Purple	Red	White	Yellow
Non-Booted	540-135-LLL	540-110-LLL	540-100-LLL	540-120-LLL	540-140-LLL	540-145-LLL	540-130-LLL	540-125-LLL	540-115-LLL
Booted	541-135-LLL	541-110-LLL	541-100-LLL	541-120-LLL	541-140-LLL	541-145-LLL	541-130-LLL	541-125-LLL	541-115-LLL
Crossover	542-135-LLL	542-110-LLL	542-100-LLL	542-120-LLL	542-140-LLL	542-145-LLL	542-130-LLL	542-125-LLL	542-115-LLL
Shielded	460-135-LLL	660-110-LLL	460-100-LLL	460-120-LLL	460-140-LLL	460-145-LLL	460-130-LLL	460-125-LLL	460-115-LLL
Solid Wire, Plenum-Rated	543-135-LLL	543-110-LLL	543-100-LLL	543-120-LLL	543-140-LLL	543-145-LLL	543-130-LLL	543-125-LLL	543-115-LLL

*LLL — Length can be customized to meet your specifications. When ordering cables please specify length in feet or meters.

Value Series Cat6 Non-Booted Patch Cords

	Black	Blue	Gray	Green	Orange	Purple	Red	White	Yellow
1 Ft.	566-135-001	566-110-001	566-100-001	566-120-001	566-140-001	566-145-001	566-130-001	566-125-001	566-115-001
3 Ft.	566-135-003	566-110-003	566-100-003	566-120-003	566-140-003	566-145-003	566-130-003	566-125-003	566-115-003
5 Ft.	566-135-005	566-110-005	566-100-005	566-120-005	566-140-005	566-145-005	566-130-005	566-125-005	566-115-005
7 Ft.	566-135-007	566-110-007	566-100-007	566-120-007	566-140-007	566-145-007	566-130-007	566-125-007	566-115-007
10 Ft.	566-135-010	566-110-010	566-100-010	566-120-010	566-140-010	566-145-010	566-130-010	566-125-010	566-115-010
14 Ft.	566-135-014	566-110-014	566-100-014	566-120-014	566-140-014	566-145-014	566-130-014	566-125-014	566-115-014
20 Ft.	566-135-020	566-110-020	566-100-020	566-120-020	566-140-020	566-145-020	566-130-020	566-125-020	566-115-020
25 Ft.	566-135-025	566-110-025	566-100-025	566-120-025	566-140-025	566-145-025	566-130-025	566-125-025	566-115-025
50 Ft.	566-135-050	566-110-050	566-100-050	566-120-050	566-140-050	566-145-050	566-130-050	566-125-050	566-115-050

Value Series Cat6 Booted Patch Cords

	Black	Blue	Gray	Green	Orange	Purple	Red	White	Yellow
1 Ft.	576-135-001	576-110-001	576-100-001	576-120-001	576-140-001	576-145-001	576-130-001	576-125-001	576-115-001
3 Ft.	576-135-003	576-110-003	576-100-003	576-120-003	576-140-003	576-145-003	576-130-003	576-125-003	576-115-003
5 Ft.	576-135-005	576-110-005	576-100-005	576-120-005	576-140-005	576-145-005	576-130-005	576-125-005	576-115-005
7 Ft.	576-135-007	576-110-007	576-100-007	576-120-007	576-140-007	576-145-007	576-130-007	576-125-007	576-115-007
10 Ft.	576-135-010	576-110-010	576-100-010	576-120-010	576-140-010	576-145-010	576-130-010	576-125-010	576-115-010
14 Ft.	576-135-014	576-110-014	576-100-014	576-120-014	576-140-014	576-145-014	576-130-014	576-125-014	576-115-014
20 Ft.	576-135-020	576-110-020	576-100-020	576-120-020	576-140-020	576-145-020	576-130-020	576-125-020	576-115-020
25 Ft.	576-135-025	576-110-025	576-100-025	576-120-025	576-140-025	576-145-025	576-130-025	576-125-025	576-115-025
50 Ft.	576-135-050	576-110-050	576-100-050	576-120-050	576-140-050	576-145-050	576-130-050	576-125-050	576-115-050

[Cat6] Patch Cords

FIBER

COPPER

AUDIO/VIDEO

PC/COMPUTER CABLES

PanelView™ Plus 6 700, 1000, 1250, and 1500 Terminals

Machine-level HMI

Features and Benefits

Application Performance

PanelView Plus 6 provides an additional competitive edge for end users and OEMs by enabling increased machine performance. Expanded memory allows for greater flexibility in applications, while increased processor speed provides the operator a better experience through faster terminal response and greater control. Both enhancements improve visibility to data and provide a platform to make better, faster decisions.

Development Enhancements

Machine builders and end-users are under constant pressure to reduce design time, increase flexibility and deliver more value – exactly what FactoryTalk View Machine Edition 6.0 and Rockwell Automation's Integrated Architecture deliver. Rockwell Automation simplifies users' enterprise-wide process visualization by using a single design environment, providing a platform to share information – even at the design stage. These tools also offer a jump start to your application development, while supplying troubleshooting tools to assist in commissioning.

Application flexibility sometimes means being able to leverage 3rd party add-ons. With PanelView Plus 6 you can do just that – further simplifying your overall machine development.

Take time and cost out of development while delivering more performance to operators and value to customers.



PanelView Plus 6 Description

Over the years Rockwell Automation has earned a reputation for offering a wide range of scalable visualization solutions, available in multiple configurations and sizes. PanelView Plus is one of the most versatile operator interface options within that suite of visualization solutions. Now Rockwell Automation is enhancing this product line by adding more power and features like expanded memory, a faster processor and Microsoft Windows CE 6 operating system.

New PanelView Plus 6 operator terminals are ideal for applications that require monitoring, controlling and displaying information in dynamic ways, where operators must quickly understand machine status and make better decisions.

Coupled with the latest, built-in FactoryTalk® View Machine Edition 6.0 and View Studio application development software, this solution extends the performance and functionality of machine-level operator interface, while retaining a common development environment and Integrated Architecture from Rockwell Automation.

PanelView Plus 6 terminals are available in a variety of modular display sizes, enabling you to select exactly what is required for your application. This provides a standard base of modules and customizable features to use across multiple applications, reducing maintenance and inventory costs.

To meet more stringent environmental conditions; high-bright, conformal-coated and marine certified displays modules are also available.

LISTEN.
THINK.
SOLVE.™

	PanelView Plus 6 700	PanelView Plus 6 1000	PanelView Plus 6 1250	PanelView Plus 6 1500
Display Size	132 x 99 mm 640 x 480 resolution	211 x 158 mm 640 x 480 resolution	246 x 184 mm 800 x 600 resolution	304 x 228 mm 1024 x 768 resolution
Display Type	Color Active Matrix (TFT 18-bit color)			
Operating System	Microsoft Windows CE 6.0 R3			
Open Architecture	Yes (SDK available)			
CPU	x86 - 1.0 GHz			
RAM	512 MiB DDR2-533 (chip-on-board) (4264MiB/s peak)			
Internal Storage	512 MB			
Real-time clock	Yes, Battery-backed time clock timestamps critical data. Accuracy +/-2 minutes per month			
Environmental Operating Temperature	0 - 55°C (32 - 131°F)			
Ratings	NEMA 12, 13, 4X, IP54, IP65			
Certifications	cUL certified; UL listed; Class I, Div 2, Groups A,B,C,D; Class II, Div 2, Groups F, G, Class III, T4, Class I Zone 2 Group IIC			
Interfaces				
SD	1 x SDHC			
USB	2 x USB-A (v2.0 high speed), 1 x Mini-USB-B (v2.0 high speed 5 pin)			
PCI	1 x PCI (3.3/5V 32-bit)			
Communication Interfaces				
Ethernet	1 x RJ45 10/100 Mb Auto-MDI/MDI-X			
RS232	1 x DB9			
ControlNet	Available via add-on module			
Data Highway Plus	Available via add-on module			
DH485	Available via add-on module			
Input Power	18-30V DC (isolated) or 85-264V AC @ 47-63 Hz			
Standard Software	FactoryTalk Machine Edition, FactoryTalk Viewpoint, PDF viewer, ActiveX controls, remote terminal control, FTP server			
Extended Software Option	Windows Media Player, Internet Explorer, Microsoft Office viewers			

Allen-Bradley, CompactLogix, ControlLogix, FactoryTalk, Kinetix, PanelView and Rockwell Software are registered trademarks of Rockwell Automation, Inc. Trademarks not belonging to Rockwell Automation are property of their respective companies.

www.rockwellautomation.com

Power, Control and Information Solutions Headquarters

Americas: Rockwell Automation, 1201 South Second Street, Milwaukee, WI 53204-2496 USA, Tel: (1) 414.382.2000, Fax: (1) 414.382.4444

Europe/Middle East/Africa: Rockwell Automation, Vorstlaan/Boulevard du Souverain 36, 1170 Brussels, Belgium, Tel: (32) 2 663 0600, Fax: (32) 2 663 0640

Asia Pacific: Rockwell Automation, Level 14, Core F, Cyberport 3, 100 Cyberport Road, Hong Kong, Tel: (852) 2887 4788, Fax: (852) 2508 1846

Catalog Number Explanation

This is the catalog number explanation for configured units of the PanelView Plus 6 terminals.

	Input Type	Display Size	Display Type	Communication ⁽¹⁾	Power	Operating System	Special Option
2711P-	K = Keypad	7 = 6.5 in.	C = Color	4 = Ethernet, RS-232 & (2) USB	A = AC	8 = Windows CE 6.0 operating system	K = Conformal-Coated
	T = Touch	10 = 10.4 in.			D = DC	9 = Windows CE 6.0 operating system with extended features	
	B = Keypad/Touch	12 = 12.1 in.					
		15 = 15 in.					

(1) Optional communication modules are available as separate catalog numbers.

Terminal Selections

The PanelView Plus 6 configured terminals have logic modules with or without extended features and file viewers. Communication modules are ordered as separate catalog numbers.

Table 6 - PanelView Plus 6 Terminals

Cat. Nos.			Display		Communication		Input Power	Memory RAM/Nonvolatile ⁽²⁾
Keypad	Touch	Keypad/Touch	Size	Type	RS-232	Ethernet		
700 Model								
2711P-K7C4D8	2711P-T7C4D8	2711P-B7C4D8	6.5-in.	Color	•	•	DC	512 MB/512 MB
–	2711P-T7C4D8K ⁽¹⁾	–			•	•	DC	512 MB/512 MB
2711P-K7C4A8	2711P-T7C4A8	2711P-B7C4A8			•	•	AC	512 MB/512 MB
1000 Model								
2711P-K10C4D8	2711P-T10C4D8	2711P-B10C4D8	10.4-in.	Color	•	•	DC	512 MB/512 MB
2711P-K10C4A8	2711P-T10C4A8	2711P-B10C4A8			•	•	AC	512 MB/512 MB
1250 Model								
2711P-K12C4D8	2711P-T12C4D8	2711P-B12C4D8	12.1-in.	Color	•	•	DC	512 MB/512 MB
–	2711P-T12C4D8K ⁽¹⁾	–			•	•	DC	512 MB/512 MB
2711P-K12C4A8	2711P-T12C4A8	2711P-B12C4A8			•	•	AC	512 MB/512 MB
1500 Model								
2711P-K15C4D8	2711P-T15C4D8	2711P-B15C4D8	15-in.	Color	•	•	DC	512 MB/512 MB
2711P-K15C4A8	2711P-T15C4A8	2711P-B15C4A8			•	•	AC	512 MB/512 MB

(1) Conformal-coated terminal.

(2) The logic module supports FactoryTalk View Machine Edition software, version 6.0 or later, FactoryTalk ViewPoint software version 1.2 or later, and the Windows CE 6.0 operating system.

Table 7 - PanelView Plus 6 Terminals with Extended Features

Cat. Nos.			Display		Communication		Input Power	Memory RAM/Nonvolatile ⁽¹⁾
Keypad	Touch	Keypad/Touch	Size	Type	RS-232	Ethernet		
700 Model								
2711P-K7C4D9	2711P-T7C4D9	2711P-B7C4D9	6.5-in.	Color	•	•	DC	512 MB/512 MB
2711P-K7C4A9	2711P-T7C4A9	2711P-B7C4A9			•	•	AC	512 MB/512 MB
1000 Model								
2711P-K10C4D9	2711P-T10C4D9	2711P-B10C4D9	10.4-in	Color	•	•	DC	512 MB/512 MB
2711P-K10C4A9	2711P-T10C4A9	2711P-B10C4A9			•	•	AC	512 MB/512 MB
1250 Model								
2711P-K12C4D9	2711P-T12C4D9	2711P-B12C4D9	12.1-in	Color	•	•	DC	512 MB/512 MB
2711P-K12C4A9	2711P-T12C4A9	2711P-B12C4A9			•	•	AC	512 MB/512 MB
1500 Model								
2711P-K15C4D9	2711P-T15C4D9	2711P-B15C4D9	15-in.	Color	•	•	DC	512 MB/512 MB
2711P-K15C4A9	2711P-T15C4A9	2711P-B15C4A9			•	•	AC	512 MB/512 MB

(1) The logic module supports FactoryTalk View Machine Edition software, version 6.0 or later, FactoryTalk ViewPoint software version 1.2 or later, and the Windows CE 6.0 operating system with extended features and file viewers.

SD Series

Long Range IP/Ethernet & Serial
MDS SD2,TM MDS SD4,TM & MDS SD9TM



Data Acquisition | Ethernet and Serial

The MDS SD Series are industrial wireless solutions that provide long distance communications over licensed radio bands, allowing users to interface to both Ethernet and serial controllers such as PLCs, RTUs and SCADA systems.

The SD radio is the latest generation of MDS licensed narrowband wireless devices and is compatible with previous generations, allowing for a smooth and controlled upgrade to existing systems. The SD models operate in licensed spectrum between 200 and 900 MHz.

Key Benefits

- Improved speed at 19.2 Kbps in 12.5 KHz channel
- Multiple serial and IP/Ethernet device connectivity on a single radio
- Full Ethernet Bridging to support TCP and UDP
- Easy migration path from serial to IP/Ethernet
- Backward integration with existing MDS x710 networks
- RoHS/WEEE compliant (lead-free construction)

Application Specific Wireless Solution



Oil & Gas

- Remote data collection from gas flow meters
- Monitor and transmit wellhead pressure and tank levels collected by RTUs



Energy

- Remote control of IED and PLC at distribution substations
- Condition monitoring for pole-top circuit breakers and capacitor banks



Water & Wastewater

- Monitor lift stations across multiple sites from control room



Heavy Industrial

- Activation of perimeter gates based on detection of vehicle
- Monitor and control remote pumps and compressors

Industrially Hardened

- Operational temperature range from -40°C to 70°C
- CSA Class I, Div. 2 groups A,B,C,D for Hazardous Locations
- IEEE1613 for electric substation environments

Application Flexibility

- Supports two serial ports and an IP/Ethernet port simultaneously
- Broad coverage flexibility over distances up to 50 miles
- Supports both Ethernet Bridging and dedicated serial to serial communications
- Low power consumption with sleep mode for solar and battery powered applications
- Fast-serial features with embedded serial to IP/Ethernet conversion

Reliable & Scalable

- Exclusive-use, non-shared licensed band operation
- Point-to-Multipoint, 2-way communication
- High receive sensitivity for long distance communications
- Compatible with multiple industry protocols including Modbus, Modbus TCP, and DNP3

Secure

- AES 128-bit data encryption
- Password protected access and lockdown



Specifications

GENERAL

Frequency Programmability	Configurable
Operational modes	Simplex, half-duplex
Modulation	Digital / CPFSK
Range	Up to 50 miles

SD2

RF data rate & bandwidth	3,200 bps @ 5 kHz 4,800 bps @ 6.25 kHz 9,600 & 19,200 bps @ 12.5 kHz 19,200 bps @ 25 kHz
Frequency bands	216 - 220 MHz 220 - 235 MHz

SD4

RF data rate & bandwidth	4,800 bps @ 6.25 kHz 9,600 & 19,200 bps @ 12.5 kHz 19,200 bps @ 25 kHz
Frequency bands	350 - 400 MHz 400 - 450 MHz 450 - 512 MHz

SD9

RF data rate & bandwidth	9,600 & 19,200 bps @ 12.5 kHz 19,200 bps @ 25 kHz
Frequency bands	928-960 MHz

TRANSMITTER

Frequency Stability	+/- 0.5 ppm
Carrier power	0.1 to 5 Watts Programmable
Carrier power Accuracy	Normal +/- 1.5 dB
Duty Cycle	Continuous
Output Impedance	50 Ohms

RECEIVER

Type	Double Conversion Superheterodyne
Bit Error Rate Selectivity	1x10 ⁻⁶ @ -112 dBm typical >70dB
Adjacent Channel Rejection	40 dB nominal

INTERFACES

Serial COM1	RS-232, DB-9
Serial COM2	RS-232, RS-485 DB-9
Ethernet	10/100 BaseT, RJ 45
Antenna	TNC Female

MANAGEMENT

MDS InSite software
MDS NetView software
MDS Radio Configuration software

ENVIRONMENTAL

Temperature	-40°C to +70°C (-40°F to +158°F)
Humidity	95% at 40C (104°F) non-condensing

ELECTRICAL

Tx Current	2.2A Typical at 5 Watts
Rx Current	<125 mA
Sleep mode	9 mA nominal

SD4

Primary power	10.5 Vdc to 16 Vdc , 10-30 Vdc pending
---------------	--

SD2, SD9

Primary power	10 Vdc to 30 Vdc
---------------	------------------

MECHANICAL

Case	Rugged die-cast aluminum
Dimensions	1.5 H x 4.625 W x 6.5 D cm (0.6 H x 1.8 W x 2.6 D in)
Weight	0.55 kg (1.22 lbs)

AGENCY APPROVALS

CSA Class 1 Div 2 for hazardous locations
IEEE 1613 substation environment
Industry Canada & ENTELA
FCC Part 80: SD2, FCC Part 90: SD2, SD4, SD9
FCC Part 95: SD2
FCC Part 101: SD9, CE, ETSI: SD4

Ordering

SD2 Remote

SD02MD	*	**	-NNSNN
Sub -band	A		216-220 MHz
	B		220-235 MHz
Model		SS	Serial
		ES	Ethernet and Serial
		MS	2710 Emulation

SD4 Remote

SD04MD-	*	**	-NNSNN
Sub -band	A		350-400 MHz
	B		400-450 MHz
	C		450-512 MHz
Model		SS	Serial
		ES	Ethernet and Serial
		MS	4710 Emulation

SD9 Remote

SD09MD-	*	**	-NNSNN
Sub -band	C		928-960 MHz
Model		SS	Serial
		ES	Ethernet and Serial
		MS	9710 Emulation

SD Adapter for x790 Series Master Stations

SDA-	*	**	
Modem	A		Pre-configured for 4790A or 9790A Master Station
	C		Pre-configured for 4790C Master Station
	E		Pre-configured for 4790E or 9790E Master Station
	M		Pre-configured for 4790M Master Station
Network		S	SD-only radio system
		X	x710 compatible system

Order Code Example

SD02MD-AES-NNSNN

- Remote radio
- 216 - 220 MHz
- Ethernet & serial communications
- Standard mounting brackets
- No special assembly

Order Code Example

SD04MD-CSS-NNSNN

- Remote radio
- 450 - 512 MHz
- Serial only communication
- Standard mounting brackets
- No special assembly

Order Code Example

SD09MD-CES-NNSNN

- Remote radio
- Ethernet and Serial
- Standard mounting brackets
- No special assembly

Order Code Example

SDA-AS

- Adaptor for master station
- Pre-configured for 9600 bps
- Pre-configured for 12.5 kHz
- Ethernet communications

Accessories for the SD Series

Fixed Remote Kits with Yagi

KFR-S04-C1 (406-430 MHz)
KFR-S04-C2 (430-450 MHz)
KFR-S04-C3 (450-470 MHz)
KFR-S09-D1 (900 MHz)
KFR-S02-A (216-235 MHz)

View Accessories catalog at www.gemds.com

Visit www.GEMDS.com/SDSeries to:



- Buy SD through the online store
- Download guideform specifications
- Download user documentation
- Read application notes and white papers

ALL DESIGN, OPERATIVE AND PROCESS DATA PERTAINING TO THE ARTICLE SHOWN ON THIS SHEET IS THE PROPERTY OF POLYPHASER CORPORATION. THE INFORMATION IS NOT TO BE COPIED, REPRODUCED, REVEALED TO OR APPROPRIATED BY OTHERS WITHOUT THE EXPRESS WRITTEN CONSENT OF POLYPHASER CORPORATION.

REVISIONS				
REV LTR	DATE	ENG	MKTG	Q.A.
D	01/11/01 ^{IB}	KCB	PH	RM
E	11/12/02 ^{SH}	LC	SD	LJ

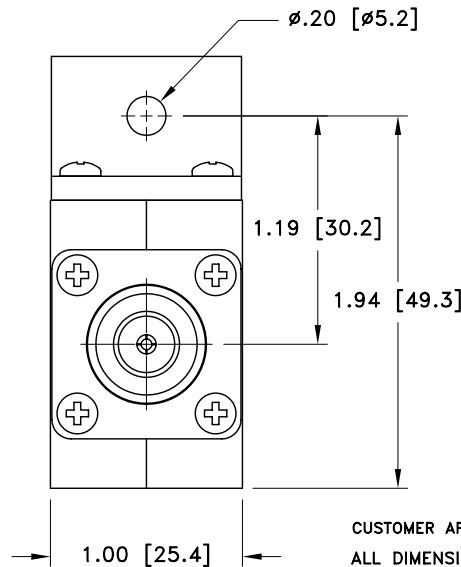
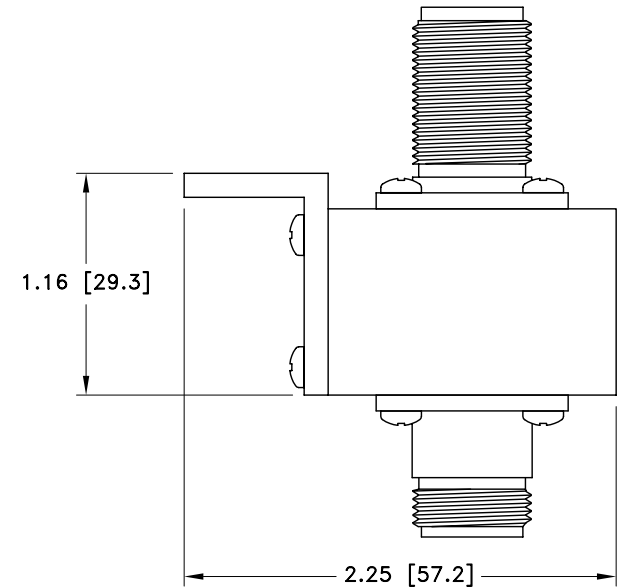
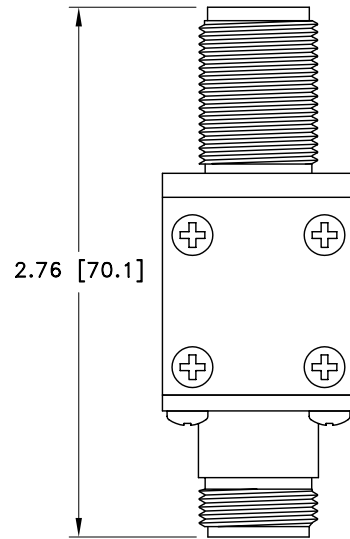
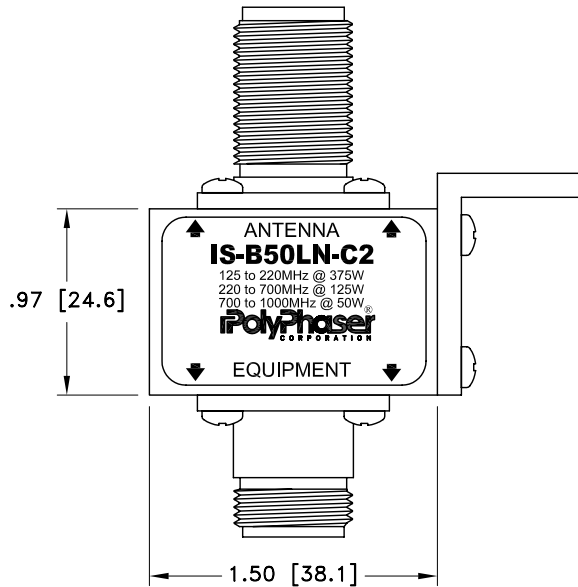







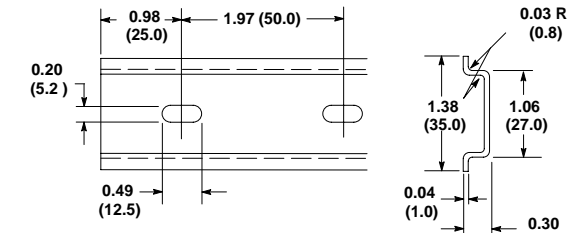
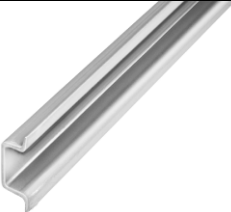
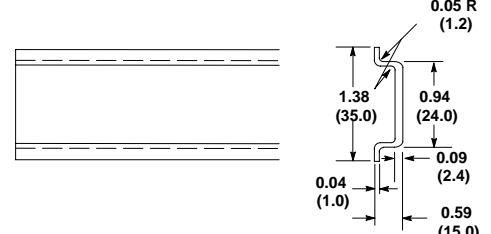

CUSTOMER APPROVAL: _____ DATE: _____

ALL DIMENSIONS SHOWN ABOVE ARE FOR REFERENCE ONLY.

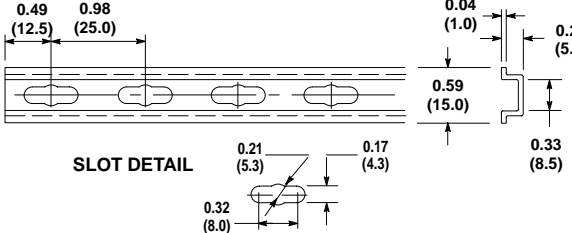
MAXIMUM CHARACTERISTICS
APPLICATION: BULKHEAD MOUNT
FREQUENCY RANGE: 125MHz TO 1GHz
VSWR: ≤1.1:1 OVER FREQUENCY RANGE
INSERTION LOSS: ≤0.1dB OVER FREQUENCY RANGE
MAX POWER: 375W @ 125MHz DECREASING TO 50W @ 1GHz
TURN-ON: 600Vdc±20%
THROUGHPUT ENERGY: ≤220μJ FOR 8/20μS WAVEFORM
OPERATING TEMPERATURE: -55°C TO +50°C
STORAGE TEMPERATURE: -55°C TO +85°C
RELATIVE HUMIDITY: 90% AT 40°C
VIBRATION 1G AT 5Hz TO 100Hz

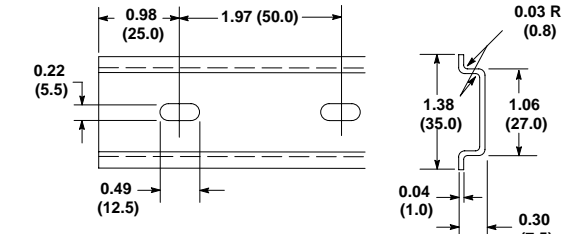
DRAFTER M. JOHNSON	DATE 07/11/94	 P.O. BOX 9000, MINDEN, NV 89423-9000 (775) 782-2511 FAX (775) 782-4476 DWG NO/PART NO/DESCRIPTION IS-B50LN-C2 CUSTOMER PRINT			
MECH ENGINEER -	DATE -				
ELEC ENGINEER K. BARTEL	DATE 05/01/95				
MARKETING -	DATE -				
QUALITY DEPT R. MATHEUS	DATE 05/01/95	CAGE CODE 61114	FILE NAME -C1	SCALE 1/1	SHEET 1 OF 1

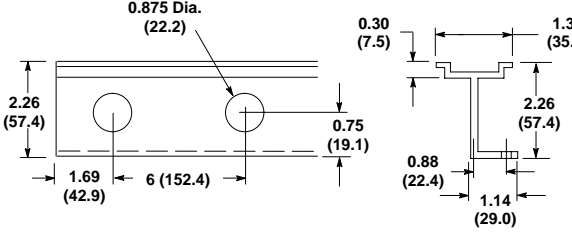
DIN Mounting Rails

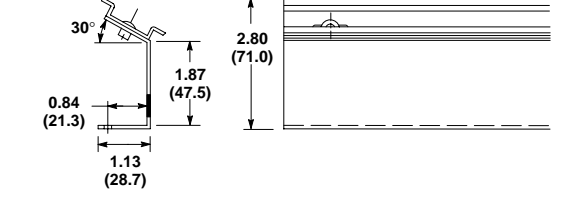
Item	Description	Pcs./Pkg.	Dimensions ①
<p>199-DR1</p> 	<p>Symmetrical Rail 35 mm x 7.5 mm 3.28' (1 m) long Zinc-Plated, Yellow Chromated Steel EN50022</p> <p>DIN #3</p>	<p>10</p>	 <p>#10–32 or M5 Recommended Maximum Mounting Screw Size</p>
<p>199-DR4</p> 	<p>Heavy Duty Symmetrical Rail 35 mm x 15 mm 3.28' (1 m) long Zinc-Plated, Yellow Chromated Steel EN50022</p> <p>DIN #3</p>	<p>5</p>	
<p>1492-DR3</p> 	<p>Mini 15 mm x 5.5 mm Rail 3.28' (1 m) long Zinc-Plated, Yellow Chromated Steel EN50045</p> <p>DIN #2</p>	<p>5</p>	 <p>#8–32 or M4 Recommended Maximum Mounting Screw Size</p>
<p>1492-DR5</p> 	<p>Symmetrical Rail 35 mm x 7.5 mm 3.28' (1 m) long Copper-Free Aluminum EN50022</p> <p>For 1492 Terminal Blocks Only</p> <p>DIN #3</p>	<p>10</p>	 <p>#12–24 or M5 Recommended Maximum Mounting Screw Size</p>
<p>1492-DR6 ②</p> 	<p>Symmetrical Rail 35 mm x 7.5 mm 2.26" (57.4 mm) high 3.28' (1 m) long Copper-Free Aluminum</p> <p>For 1492 Terminal Blocks Only</p> <p>DIN #3</p>	<p>2</p>	 <p>Wire insulator plug for wire access through rail — use Heyco</p>
<p>1492-DR7 ②</p> 	<p>Symmetrical Rail 35 mm x 7.5 mm 2.80" (71.0 mm) high 3.28' (1 m) long Angled 30° Zinc-Plated, Chromated Steel</p> <p>DIN #3</p>	<p>2</p>	 <p>For mounting rail details, see Cat. No. 199-DR1</p>

① Dimensions shown in inches (millimeters). Dimensions are not intended to be used for manufacturing purposes.
 ② 0.218" (5.5 mm) x 0.50" (12.7 mm) slotted mounting holes every 3" (76.2 mm) starting 1.69" (42.9 mm) from end.

Screw Connection Terminal Blocks

Standard Feed-Through Blocks

1492-J3

1492-J4

1492-J6

Dimensions are not intended to be used for manufacturing purposes.
Note: Height dimension is measured from top of rail to top of terminal block.

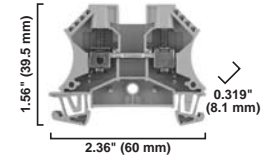
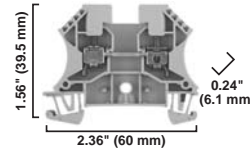
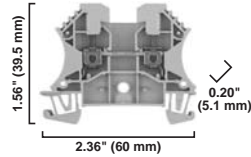

Specifications	Feed-Through Terminal Block				Feed-Through Terminal Block				Feed-Through Terminal Block			
	UL	CSA	IEC	ATEX	UL	CSA	IEC	ATEX	UL	CSA	IEC	ATEX
Certifications	UL	CSA	IEC	ATEX	UL	CSA	IEC	ATEX	UL	CSA	IEC	ATEX
Voltage Rating	600V AC/DC				600V AC/DC				600V AC/DC			
Maximum Current	65 A	50 A	24 A	21 A	35 A	25 A	32 A	28 A	50 A	41 A	36 A	36 A
Wire Range (Rated Cross Section)	#22... 12 AWG	#26... 12 AWG	2.5 mm ²	2.5 mm ² (#20... 14 AWG)	#22... 10 AWG	#26... 10 AWG	4 mm ²	4 mm ² (#20... 12 AWG)	#22...8 AWG	6 mm ²	6 mm ² (#20... 10 AWG)	6 mm ² (#20... 10 AWG)
Wire Strip Length	0.39 in. (10 mm)				0.39 in. (10 mm)				0.47 in (12 mm)			
Recommended Tightening Torque	4.5...7.1 lb•in. (0.5...0.8 N•m)				9.0 lb•in. (1.0 N•m)				14.2 lb•in (1.6 N•m)			
Density	59 pcs/ft (196 pcs/m)				49 pcs/ft (163 pcs/m)				37 pcs/ft (123 pcs/m)			
Housing Temperature Range	-58...+248 °F (-50...+120 °C)				-58...+248 °F (-50...+120 °C)				-58...+248 °F (-50...+120 °C)			
Short-Circuit Current Rating	See page 12-43											

Terminal Blocks	Cat. No.	Pkg Qty.	Cat. No.	Pkg Qty.	Cat. No.	Pkg Qty.	
Color:	Grey	1492-J3	100	1492-J4	100	1492-J6	100
	Red	1492-J3-RE	100	1492-J4-RE	100	1492-J6-RE	100
	Blue	1492-J3-B	100	1492-J4-B	100	1492-J6-B	100
	Black	1492-J3-BL	100	1492-J4-BL	100	1492-J6-BL	100
	Green	1492-J3-G	100	1492-J4-G	100	1492-J6-G	100
	Yellow	1492-J3-Y	100	1492-J4-Y	100	1492-J6-Y	100
	Orange	1492-J3-OR	100	1492-J4-OR	100	1492-J6-OR	100
	Brown	1492-J3-BR	100	1492-J4-BR	100	1492-J6-BR	100
	White	1492-J3-W	100	1492-J4-W	100	1492-J6-W	100

Accessories	Cat. No.	Pkg Qty.	Cat. No.	Pkg Qty.	Cat. No.	Pkg Qty.
Mounting Rails:						
1 m Symmetrical DIN (Steel)	199-DR1	10	199-DR1	10	199-DR1	10
1 m Symmetrical DIN (Aluminum)	1492-DR5	10	1492-DR5	10	1492-DR5	10
1 m Hi-Rise Sym. DIN (Aluminum)	1492-DR6	2	1492-DR6	2	1492-DR6	2
1 m Angled Hi-Rise Sym. DIN (Steel)	1492-DR7	2	1492-DR7	2	1492-DR7	2
End Barriers						
Grey	1492-EBJ3	50	1492-EBJ3	50	1492-EBJ3	50
Blue	1492-EBJ3-B	50	1492-EBJ3-B	50	1492-EBJ3-B	50
Yellow	1492-EBJ3-Y	50	1492-EBJ3-Y	50	1492-EBJ3-Y	50
End Anchors and Retainers:						
Screwless End Retainer	1492-ERL35	20	1492-ERL35	20	1492-ERL35	20
DIN Rail — Normal Duty	1492-EAJ35	100	1492-EAJ35	100	1492-EAJ35	100
DIN Rail — Heavy Duty	1492-EAHJ35	50	1492-EAHJ35	50	1492-EAHJ35	50
Jumpers:*						
Screw Center Jumper — 10-pole	1492-CJJ5-10	20	1492-CJJ6-10	20	1492-CJJ8-10	20
Screw Center Jumper — 4-pole	1492-CJJ5-4	50	1492-CJJ6-4	50	1492-CJJ8-4	50
Screw Center Jumper — 3-pole	1492-CJJ5-3	50	1492-CJJ6-3	50	1492-CJJ8-3	50
Screw Center Jumper — 2-pole	1492-CJJ5-2	50	1492-CJJ6-2	50	1492-CJJ8-2	50
Plug-in Center Jumper — 50-Pole	1492-CJLJ5-50	10	1492-CJLJ6-41 (41-pole)	10	—	—
Plug-in Center Jumper — 10-Pole	1492-CJLJ5-10	20	1492-CJLJ6-10	20	—	—
Plug-in Center Jumper — 9-Pole	1492-CJLJ5-9	20	—	—	—	—
Plug-in Center Jumper — 8-Pole	1492-CJLJ5-8	20	—	—	—	—
Plug-in Center Jumper — 7-Pole	1492-CJLJ5-7	20	—	—	—	—
Plug-in Center Jumper — 6-Pole	1492-CJLJ5-6	20	—	—	—	—
Plug-in Center Jumper — 5-Pole	1492-CJLJ5-5	20	—	—	—	—
Plug-in Center Jumper — 4-Pole	1492-CJLJ5-4	60	1492-CJLJ6-4	60	—	—
Plug-in Center Jumper — 3-Pole	1492-CJLJ5-3	60	1492-CJLJ6-3	60	—	—
Plug-in Center Jumper — 2-Pole	1492-CJLJ5-2	60	1492-CJLJ6-2	60	—	—
Insulated Side Jumper — 24-Pole	1492-SJ5B-24	50	—	—	—	—
Insulated Side Jumper — 10-Pole	1492-SJ5B-10	50	—	—	—	—
Screw Type Jumper Notching Tool	1492-T1	1	1492-T1	1	1492-T1	1
Other Accessories:						
Partition Plate	1492-EBJ16	20	1492-EBJ16	20	1492-EBJ16	20
Test Plug Socket	1492-TPS23	20	1492-TPS23L	50	1492-TPS23L	50
Test Plug	1492-TP23	20	1492-TP23	20	1492-TP23	20
Test Plug (Stackable)	1492-TPJ5	25	1492-TPJ6	25	—	—
Electrical Warning Plate	1492-EWPJ5	25	1492-EWPJ5	25	1492-EWPJ8	50
Group Marking Carrier	1492-GM35	25	1492-GM35	25	1492-GM35	25
Marking Systems:						
Snap-in Marker Cards	1492-M5X12 (144/card)	5	1492-M6X12 (120/card)	5	1492-MR8X12 (84/card)	5
	1492-M5X5 (200/card)	5	1492-M6X5 (200/card)	5	1492-M8X5 (160/card)	5

* Use of center jumpers may affect spacings, requiring derating of terminal blocks. See page 12-78 for details.

Screw Connection Terminal Blocks

Grounding Blocks, Continued

	1492-JG4				1492-JG4TW			1492-JG4Q		
Dimensions are not intended to be used for manufacturing purposes. Note: Height dimension is measured from top of rail to top of terminal block.										
Specifications	<i>Feed-Through Ground Block</i>				<i>Single-level ground block with twin connection points on one side</i>			<i>Single-level ground block with twin connection points on both sides</i>		
Certifications	UL	CSA	IEC	ATEX	UL	CSA	IEC	UL	CSA	IEC
Voltage Rating	—	—	—	—	—	—	—	—	—	—
Maximum Current	Grounding				Grounding			Grounding		
Wire Range (Rated Cross Section)	#22...10 AWG		4 mm ²	4 mm ² (#20...12 AWG)	#30...10 AWG		0.5...4 mm ²	#30...10 AWG		0.5...4 mm ²
Wire Strip Length	0.39 in. (10 mm)				0.394 in. (10 mm)			0.394 in. (10 mm)		
Recommended Tightening Torque	9 lb•in. (1.0 N•m)				6.2 lb•in. (0.7 N•m)			6.2 lb•in. (0.7 N•m)		
Mounting Torque - Center Screw	4.4...7.1 lb•in. (0.5...0.8 N•m)				—			—		
Density	49 pcs/ft (163 pcs/m)				49 pcs/ft (163 pcs/m)			49 pcs/ft (163 pcs/m)		
Housing Temperature Range	-58...+248 °F (-50...+120 °C)				-58...+248 °F (-50...+120 °C)			-58...+248 °F (-50...+120 °C)		
Short-Circuit Current Rating	See page 12-43									
Terminal Blocks	Cat. No.	Pkg Qty.	Cat. No.	Pkg Qty.	Cat. No.	Pkg Qty.	Cat. No.	Pkg Qty.	Cat. No.	Pkg Qty.
Color: Green/Yellow	1492-JG4	100	1492-JG4TW	50	1492-JG4Q	50				
Accessories	Cat. No.	Pkg Qty.	Cat. No.	Pkg Qty.	Cat. No.	Pkg Qty.	Cat. No.	Pkg Qty.	Cat. No.	Pkg Qty.
Mounting Rails:										
1 m Symmetrical DIN (Steel)	199-DR1	10	199-DR1	10	199-DR1	10				
1 m Symmetrical DIN (Aluminum)	1492-DR5	10	1492-DR5	10	1492-DR5	10				
1 m Hi-Rise Sym. DIN (Aluminum)	1492-DR6	2	1492-DR6	2	1492-DR6	2				
1 m Angled Hi-Rise Sym. DIN (Steel)	1492-DR7	2	1492-DR7	2	1492-DR7	2				
End Barrier Yellow	Not Required	—	1492-EBJ4TW-Y	50	1492-EBJ4Q-Y	50				
End Anchors:										
Screwless End Retainer	1492-ERL35	20	1492-ERL35	20	1492-ERL35	20				
DIN Rail - Normal Duty	1492-EAJ35	100	1492-EAJ35	100	1492-EAJ35	100				
DIN Rail - Heavy Duty	1492-EAHJ35	50	1492-EAHJ35	50	1492-EAHJ35	50				
Group Marking Rail Mount Group Marking Carrier	1492-GM35	25	1492-GM35	25	1492-GM35	25				
End Anchor Top Marker Carrier*	—	—	1492-GMC	50	1492-GMC	50				
Cat. No. 1492-GMC Top Marker Tag	—	—	1492-M5X30 (20/card)	5	1492-M5X30 (20/card)	5				
Marking Systems:										
Snap-in marker cards	1492-M6X12 (120/card)	5	1492-MR6X12 (120/card)	5	1492-MR6X12 (120/card)	5				
Snap-in marker cards	1492-M6X5 (200/card)	5	1492-M6X12 (120/card)	5	1492-M6X12 (120/card)	5				

* The Bulletin 1492-GMC marker carrier installs directly on the top of a 1492-EAJ35 end anchor or a 1492-ERL35 end retainer for group marking purposes.

Screw Connection Terminal Blocks

Multi-Circuit Feed-Through Blocks

	1492-JD3				1492-JD4				1492-JT3M					
Dimensions are not intended to be used for manufacturing purposes. Note: Height dimension is measured from top of rail to top of terminal block.														
	Specifications				<i>Two-Level Feed-Through Terminal Block</i>				<i>Two-Level, two-circuit feed-through terminal block</i>				<i>Three-level, three-circuit terminal block with ground point</i>	
Certifications		CSA	IEC	ATEX		CSA	IEC	ATEX		CSA	IEC			
Voltage Rating	600V AC/DC	300V AC/DC	400V AC/DC	275V AC/DC	600V AC/DC	300V AC/DC	800V AC/DC	550V AC/DC	300V AC/DC		400V AC/DC			
Maximum Current	20 A	10 A	24 A	21 A	35 A	30 A	32 A	28 A	10 A		24 A			
Wire Range (Rated Cross Section)	#22...12 AWG	26...12 AWG	2.5 mm ²	2.5 mm ² (20...14 AWG)	#26...10 AWG		0.5...4 mm ²	4 mm ² (20...12 AWG)	#22...12 AWG	#26...10 AWG	0.5...2.5 mm ²			
Wire Strip Length	0.39 in. (10 mm)				0.315 in. (8 mm)				0.28 in. (7 mm)					
Recommended Tightening Torque	4.5...7.1 lb•in. (0.5...0.8 N•m)				4.5 lb•in. (0.5 N•m)				4.4 lb•in. (0.5 N•m)					
Density	59 pcs/ft (196 pcs/m)				49 pcs/ft (163 pcs/m)				49 pcs/ft (163 pcs/m)					
Housing Temperature Range	-58...+248 °F (-50...+120 °C)				-58...+248 °F (-50...+120 °C)				-58...+248 °F (-50...+120 °C)					
Short-Circuit Current Rating	See page 12-43													
Terminal Blocks		Cat. No.	Pkg Qty.		Cat. No.	Pkg Qty.		Cat. No.	Pkg Qty.		Pkg Qty.			
Color:	Grey	1492-JD3	100		1492-JD4	100		1492-JT3M	50					
	Red	1492-JD3-RE	100		1492-JD4-RE	100		—	—					
	Blue	1492-JD3-B	100		1492-JD4-B	100		—	—					
	Black	1492-JD3-BL	100		1492-JD4-BL	100		—	—					
	Green	1492-JD3-G	100		1492-JD4-G	100		—	—					
	Yellow	1492-JD3-Y	100		1492-JD4-Y	100		—	—					
	Orange	1492-JD3-OR	100		1492-JD4-O	100		—	—					
	Brown	1492-JD3-BR	100		1492-JD4-BR	100		—	—					
	White	1492-JD3-W	100		1492-JD4-W	100		—	—					
Accessories		Cat. No.	Pkg Qty.		Cat. No.	Pkg Qty.		Cat. No.	Pkg Qty.		Pkg Qty.			
Mounting Rails:														
1 m Symmetrical DIN (Steel)		199-DR1	10		199-DR1	10		199-DR1	10					
1 m Symmetrical DIN (Aluminum)		1492-DR5	10		1492-DR5	10		1492-DR5	10					
1 m Hi-Rise Sym. DIN (Aluminum)		1492-DR6	2		1492-DR6	2		1492-DR6	2					
1 m Angled Hi-Rise Sym. DIN (Steel)		1492-DR7	2		1492-DR7	2		1492-DR7	2					
End Barrier	Grey	1492-EBJD3	20		1492-EBJD4	20		1492-EBJ3TM	20					
	Blue	1492-EBJD3-B	20		1492-EBJD4-B	20		—	—					
	Yellow	1492-EBJD3-Y	20		—	—		—	—					
End Anchor and Retainers:														
Screwless End Retainer		1492-ERL35	20		—	—		—	—					
DIN Rail — Normal Duty		1492-EAJ35	100		—	—		—	—					
DIN Rail — Heavy Duty		1492-EAHJ35	50		1492-EAHJ35	50		1492-EAHJ35	50					
Jumpers:														
Screw Center Jumper — 10-pole		—	—		1492-CJLJ6-41	10		—	—					
Screw Center Jumper — 10-pole		1492-CJJ5-10	20		1492-CJLJ6-10	20		—	—					
Screw Center Jumper — 4-pole		1492-CJJ5-4	50		1492-CJLJ6-4	60		—	—					
Screw Center Jumper — 3-pole		1492-CJJ5-3	50		1492-CJLJ6-3	60		—	—					
Screw Center Jumper — 2-pole		1492-CJJ5-2	50		1492-CJLJ6-2	60		—	—					
Insulated Side Jumper — 50-Pole		—	—		—	—		1492-SJ6A-50	5					
Insulated Side Jumper — 24-Pole		1492-SJ5A-24	50		—	—		—	—					
Insulated Side Jumper — 10-Pole		1492-SJ5A-10	50		—	—		—	—					
Screw Type Jumper Notching Tool		1492-T1	1		—	—		—	—					
Other Accessories:														
Partition Plate		1492-PPJD3	20		1492-PPJD3	20		1492-PPJD3	20					
Test Plug Socket		1492-TPS23	20		—	—		—	—					
Test Plug		1492-TP23	20		—	—		—	—					
Group Marking Carrier		1492-GM35	25		1492-GM35	25		1492-GM35	25					
Marking Systems:														
Snap-in marker cards		1492-M5X8 (144/card)	5		1492-MR6X8 (120/card)	5		1492-MR6X8 (120/card)	5					
Snap-in marker cards		1492-M5X5 (200/card)	5		1492-M6X5 (200/card)	5		1492-M6X5 (200/card)	5					

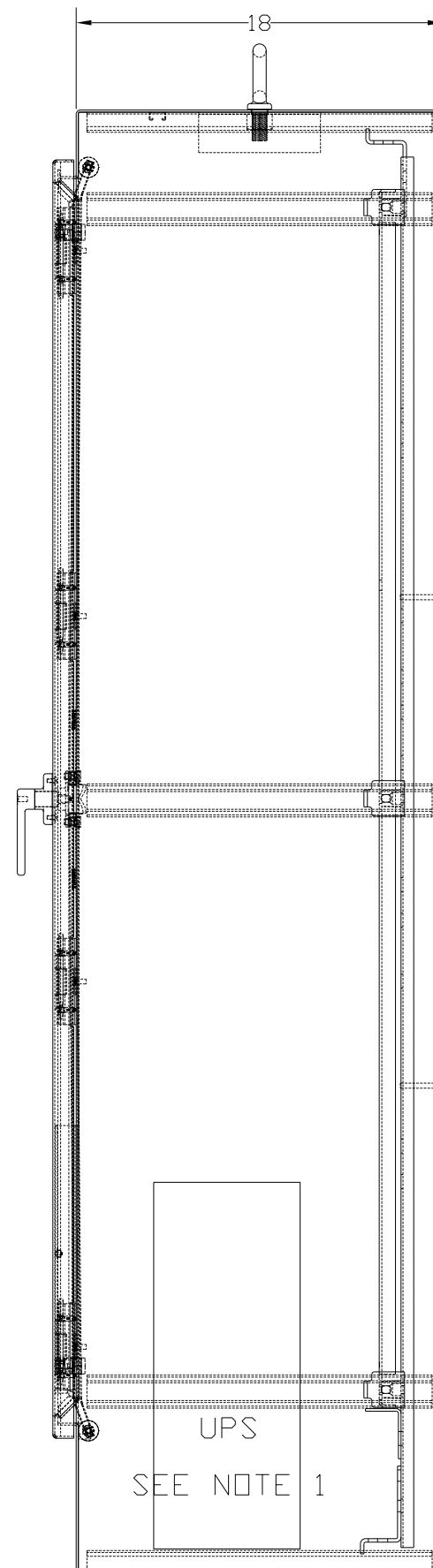
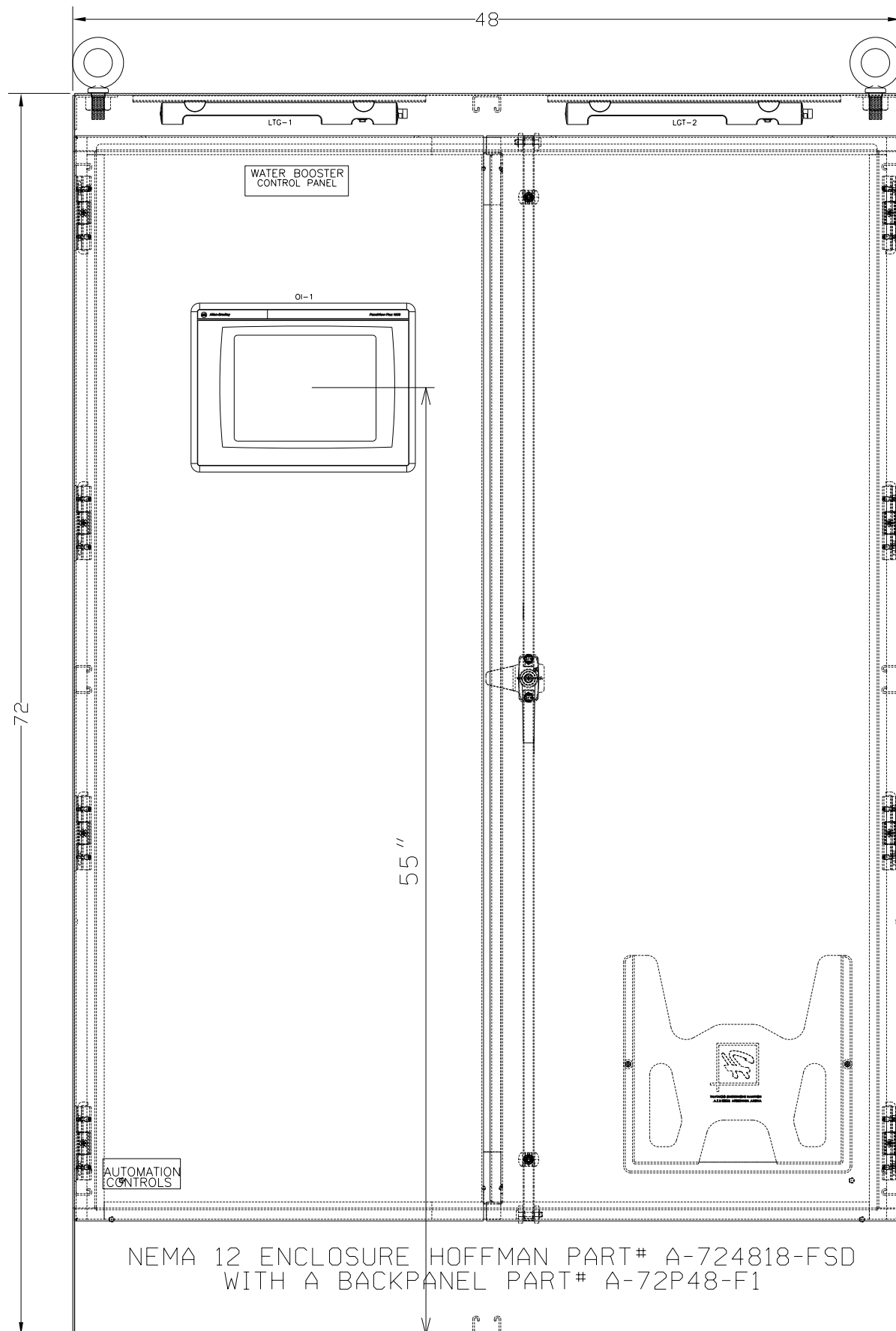

PANEL TO BE UL LISTED (usUL, cUL)
 INDUSTRIAL CONTROL PANEL
 UL508A FILE NO E109698

NOTES:
 1) UPS IS NOT
 PART OF UL LISTED
 ENCLOSURE

REV	DATE	PURPOSE:	BY	CHKD

YOUR COMPANY
 YOUR ADDRESS
 YOUR PHONE NO.
 YOUR WEBSITE

DESIGNED	DATE	FOR:
	4/2013	YOUR CUSTOMER
DRAWN	DATE	
	4/2013	
CHECKED	DATE	
DKS	08/2013	

THIS DRAWING, AND ALL REPRESENTED DATA, ARE THE PROPERTY OF THE NAMED COMPANY IN THE TITLE BLOCK. THIS DRAWING SHALL NOT BE REPRODUCED, COPIED, OR DISCLOSED EXCEPT FOR MAINTENANCE PURPOSES BY THE USING CUSTOMER.

ENCLOSURE LAYOUT
 WATER BOOSTER STATION
 SCADA PANEL
 DRAWING SET:
 2012-398 SCADA PANEL

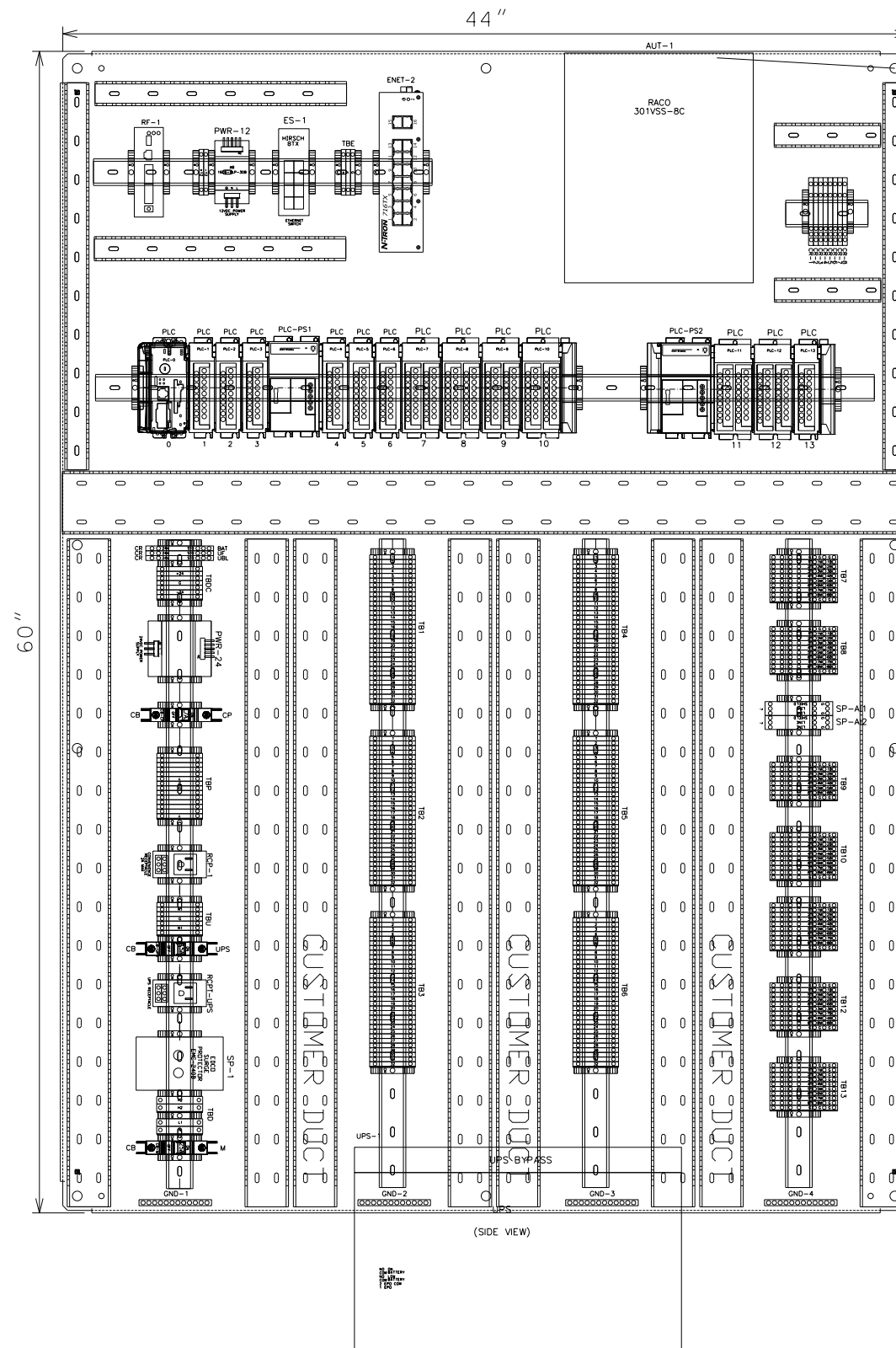

REV	DATE	PURPOSE:	BY	CHKD

YOUR COMPANY
 YOUR ADDRESS
 YOUR PHONE NO.
 YOUR WEBSITE

DESIGNED	DATE
DRAWN	DATE
CHECKED DKS	DATE

FOR:
 YOUR CUSTOMER

THIS DRAWING, AND ALL REPRESENTED DATA, ARE THE PROPERTY OF THE NAMED COMPANY IN THE TITLE BLOCK. THIS DRAWING SHALL NOT BE REPRODUCED, COPIED, OR DISCLOSED EXCEPT FOR MAINTENANCE PURPOSES BY THE USING CUSTOMER.

BACKPANEL LAYOUT
 WATER BOOSTER STATION
 SCADA PANEL

DRAWING SET:
 2012-398 SCADA PANEL

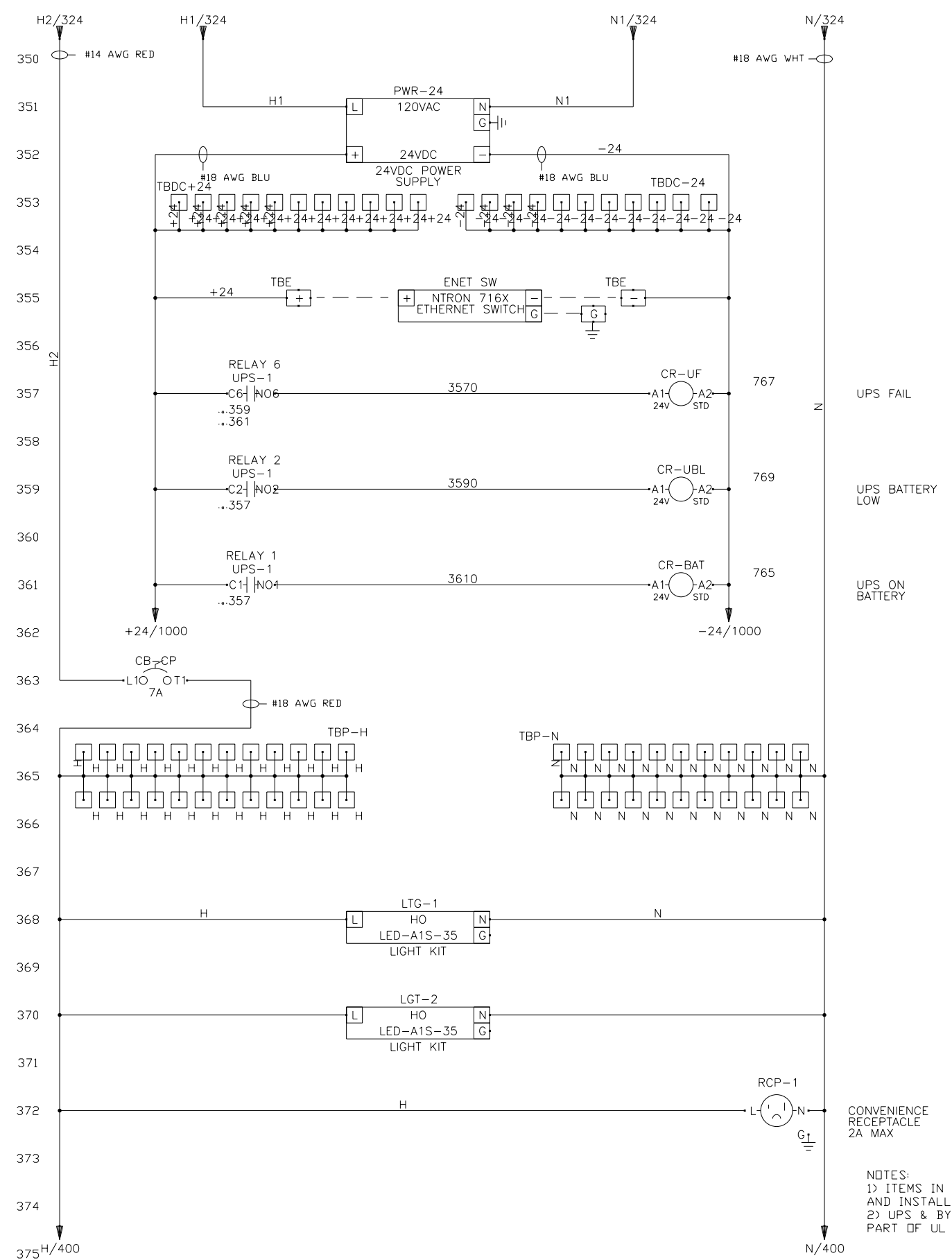
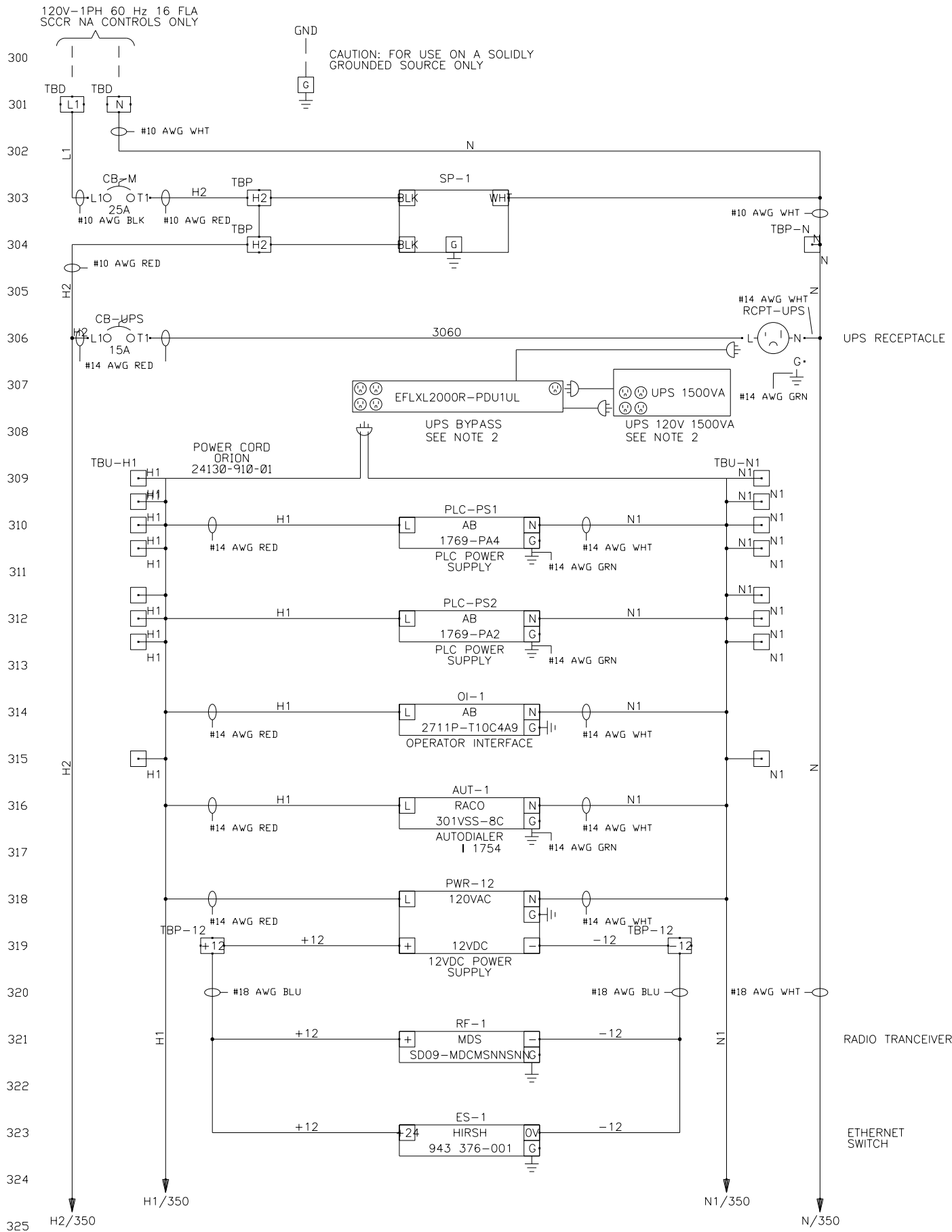

NOTES:
 1) ITEMS IN DASHED LINES PROVIDED AND INSTALLED BY OTHERS
 2) UPS & BYPASS SWITCH ARE NOT PART OF UL LISTED ENCLOSURE

REV	DATE	PURPOSE:	BY	CHKD



DESIGNED	DATE	FOR:
RN	4/2013	YOUR CUSTOMER
DRAWN	DATE	
RN	4/2013	
CHECKED	DATE	
DKS	08/2013	

THIS DRAWING, AND ALL REPRESENTED DATA, ARE THE PROPERTY OF THE NAMED COMPANY IN THE TITLE BLOCK. THIS DRAWING SHALL NOT BE REPRODUCED, COPIED, OR DISCLOSED EXCEPT FOR MAINTENANCE PURPOSES BY THE USING CUSTOMER.

CONTROL SCHEMATIC	SHEET:
WATER BOOSTER STATION SCADA PANEL	3 OF 22
DRAWING SET: 2012-398 SCADA PANEL	

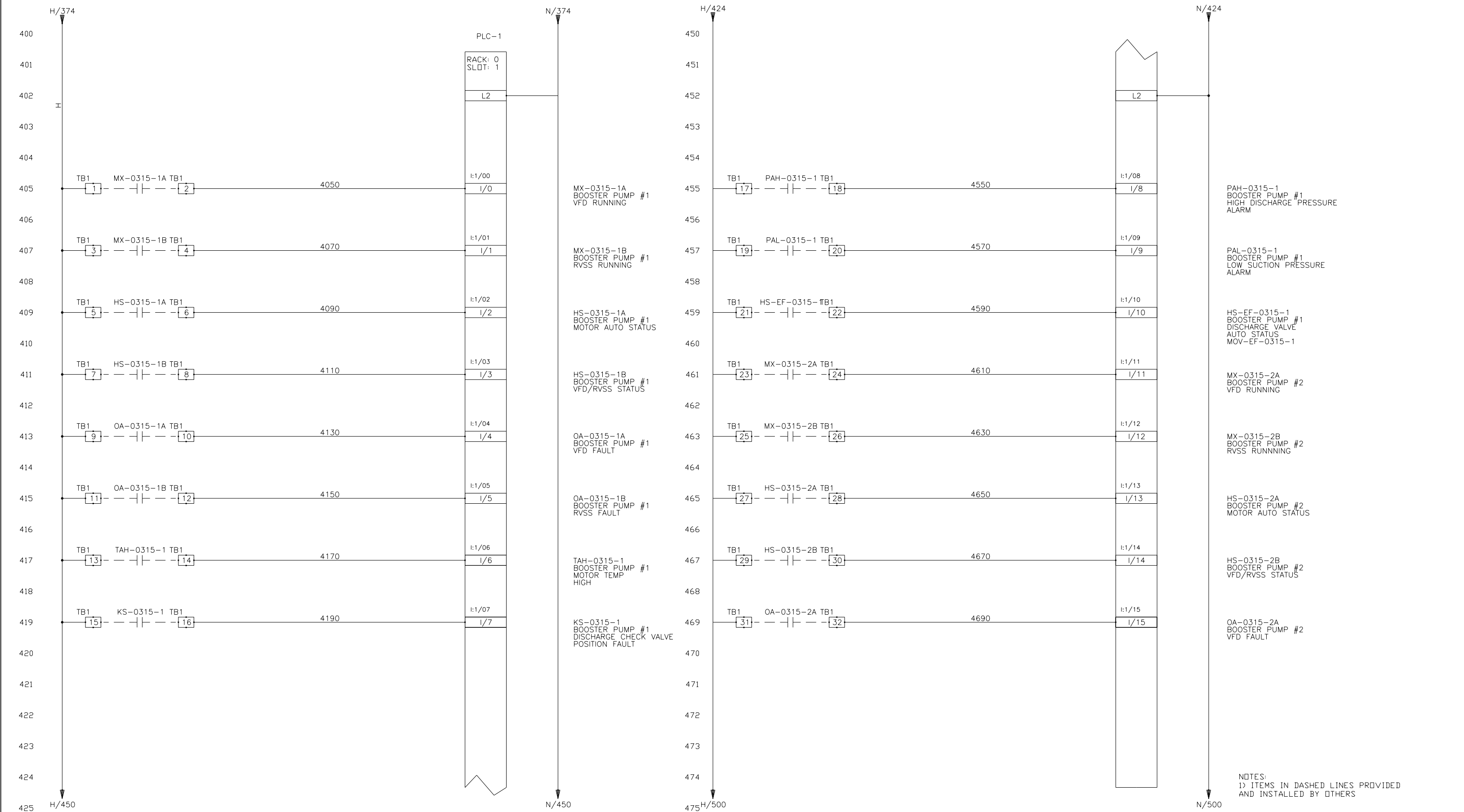

REV	DATE	PURPOSE:	BY	CHKD	DESIGNED RN	DATE	FOR:	WATER BOOSTER STATION SCADA PANEL
					RN	4/2013	YOUR CUSTOMER	
					RN	4/2013	THIS DRAWING, AND ALL REPRESENTED DATA, ARE THE PROPERTY OF THE NAMED COMPANY IN THE TITLE BLOCK. THIS DRAWING SHALL NOT BE REPRODUCED, COPIED, OR DISCLOSED EXCEPT FOR MAINTENANCE PURPOSES BY THE USING CUSTOMER.	DRAWING SET:
					DKS	08/2013		2012-398 SCADA PANEL
								SHEET:
								4 OF 22



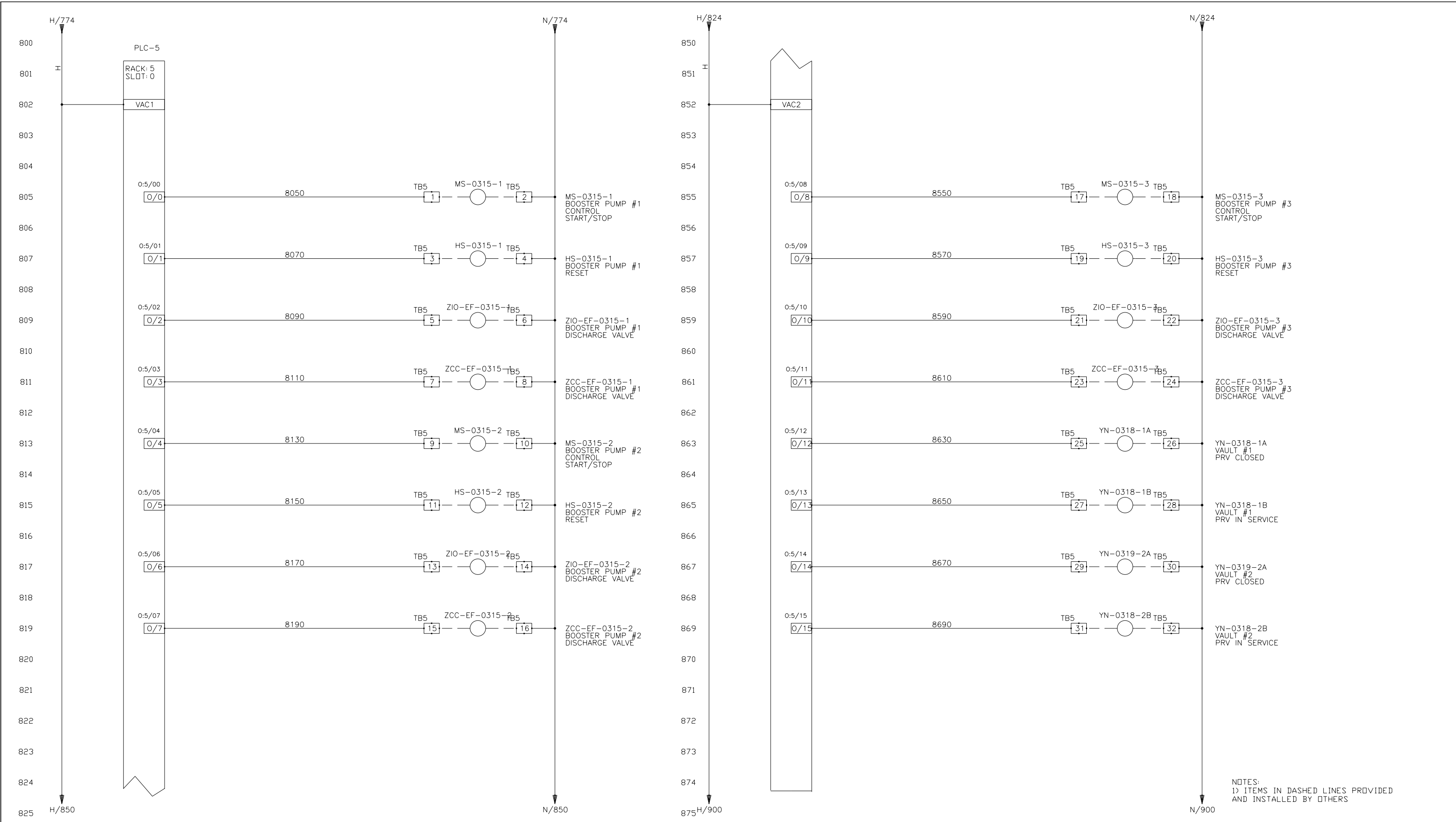

NOTES:
 1) ITEMS IN DASHED LINES PROVIDED
 AND INSTALLED BY OTHERS

REV	DATE	PURPOSE:	BY	CHKD



DESIGNED RN	DATE 4/2013
DRAWN RN	DATE 4/2013
CHECKED DKS	DATE 08/2013

FOR:
 YOUR CUSTOMER

THIS DRAWING, AND ALL REPRESENTED DATA, ARE THE PROPERTY OF THE NAMED COMPANY IN THE TITLE BLOCK. THIS DRAWING SHALL NOT BE REPRODUCED, COPIED, OR DISCLOSED EXCEPT FOR MAINTENANCE PURPOSES BY THE USING CUSTOMER.

CONTROL SCHEMATIC WATER BOOSTER STATION SCADA PANEL	DRAWING SET: 2012-398 SCADA PANEL	SHEET: 8 OF 22
---	--------------------------------------	-------------------

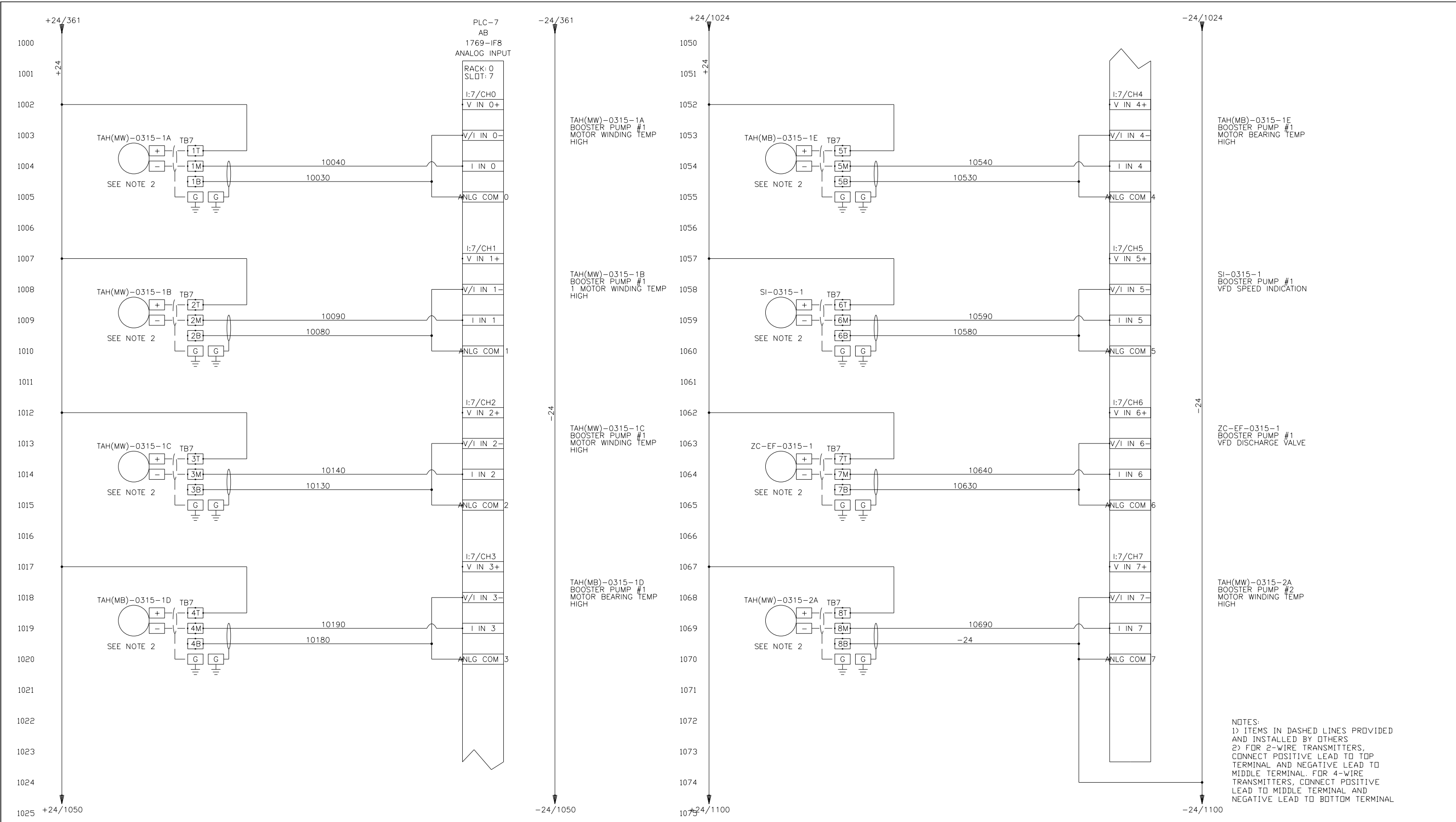

REV	DATE	PURPOSE:	BY	CHKD	DESIGNED RN	DATE 4/2013	FOR: YOUR CUSTOMER	CONTROL SCHEMATIC WATER BOOSTER STATION SCADA PANEL	
					DRAWN RN	4/2013	THIS DRAWING, AND ALL REPRESENTED DATA, ARE THE PROPERTY OF THE NAMED COMPANY IN THE TITLE BLOCK. THIS DRAWING SHALL NOT BE REPRODUCED, COPIED, OR DISCLOSED EXCEPT FOR MAINTENANCE PURPOSES BY THE USING CUSTOMER.		
					CHECKED DKS	08/2013			
YOUR COMPANY YOUR ADDRESS YOUR PHONE NO. YOUR WEBSITE								DRAWING SET: 2012-398 SCADA PANEL	SHEET: 10 OF 22

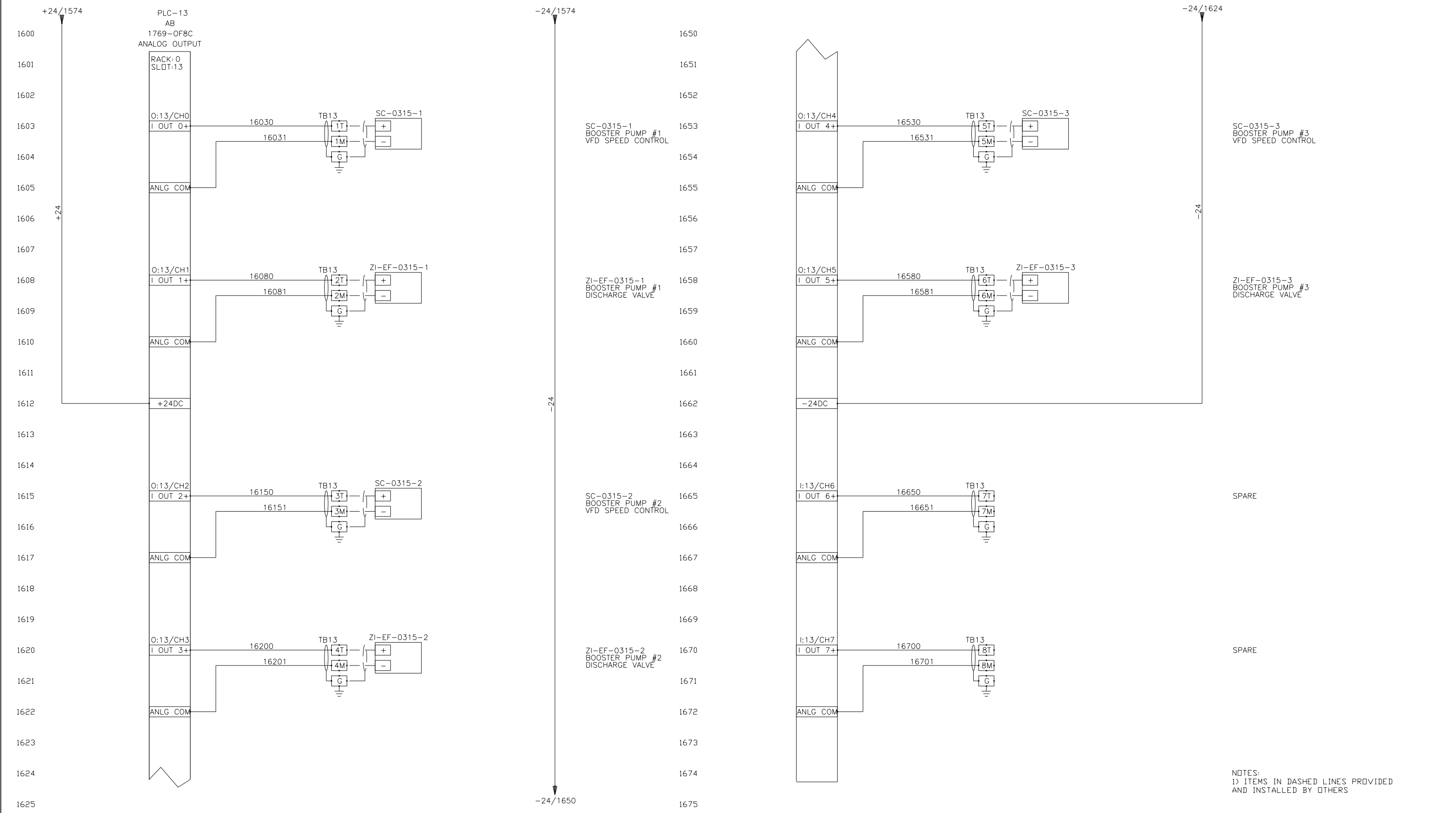

NOTES:
 1) ITEMS IN DASHED LINES PROVIDED
 AND INSTALLED BY OTHERS

REV	DATE	PURPOSE:	BY	CHKD

YOUR COMPANY
 YOUR ADDRESS
 YOUR PHONE NO.
 YOUR WEBSITE

DESIGNED	DATE	FOR:
RN	4/2013	YOUR CUSTOMER
DRAWN	DATE	
RN	4/2013	
CHECKED	DATE	
DKS	08/2013	

THIS DRAWING, AND ALL REPRESENTED DATA, ARE THE PROPERTY OF THE NAMED COMPANY IN THE TITLE BLOCK. THIS DRAWING SHALL NOT BE REPRODUCED, COPIED, OR DISCLOSED EXCEPT FOR MAINTENANCE PURPOSES BY THE USING CUSTOMER.

CONTROL SCHEMATIC WATER BOOSTER STATION SCADA PANEL	
DRAWING SET: 2012-398 SCADA PANEL	SHEET: 16 OF 22

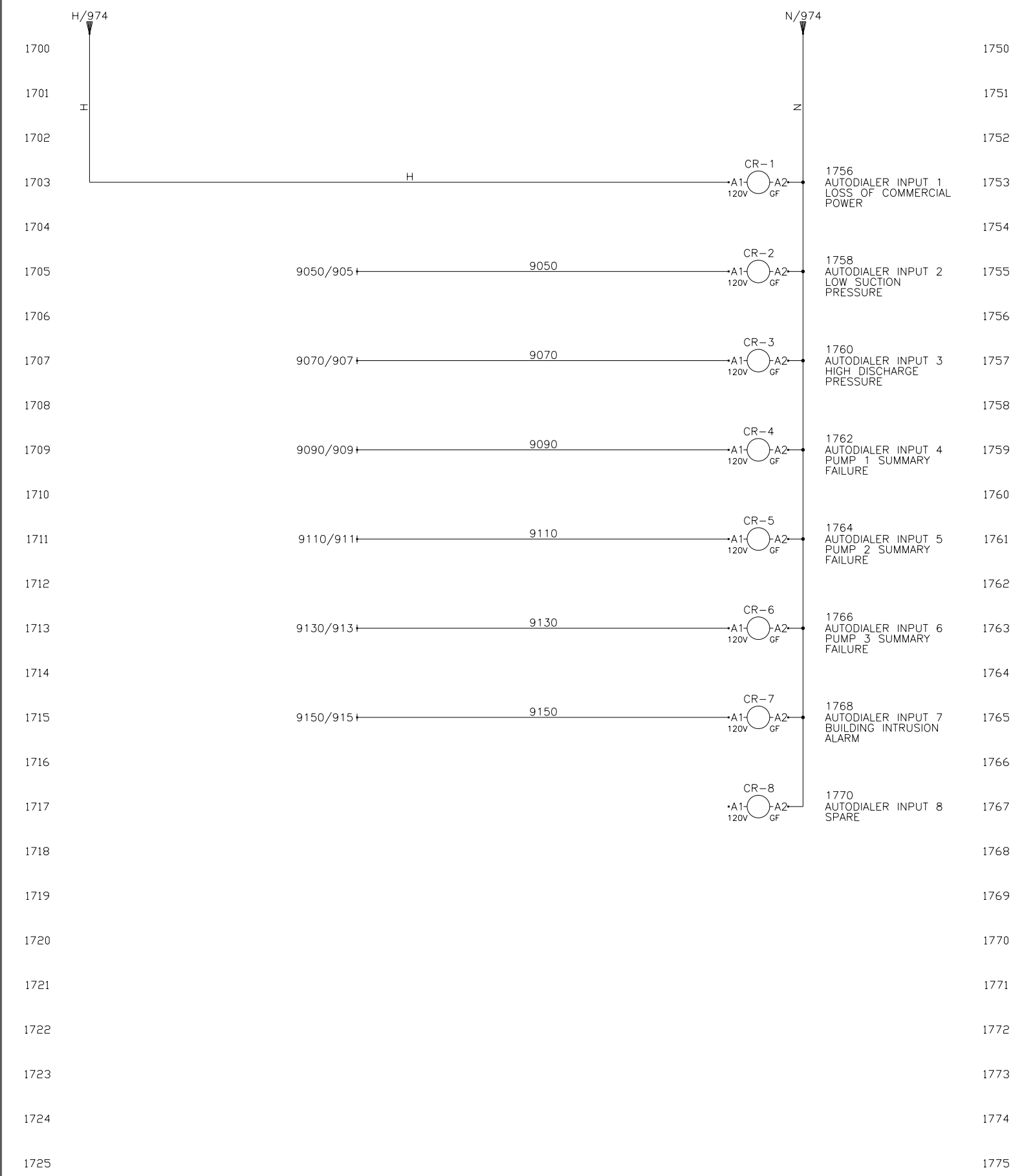

1750
1751
1752
1753
1754
1755
1756
1757
1758
1759
1760
1761
1762
1763
1764
1765
1766
1767
1768
1769
1770
1771
1772
1773
1774
1775

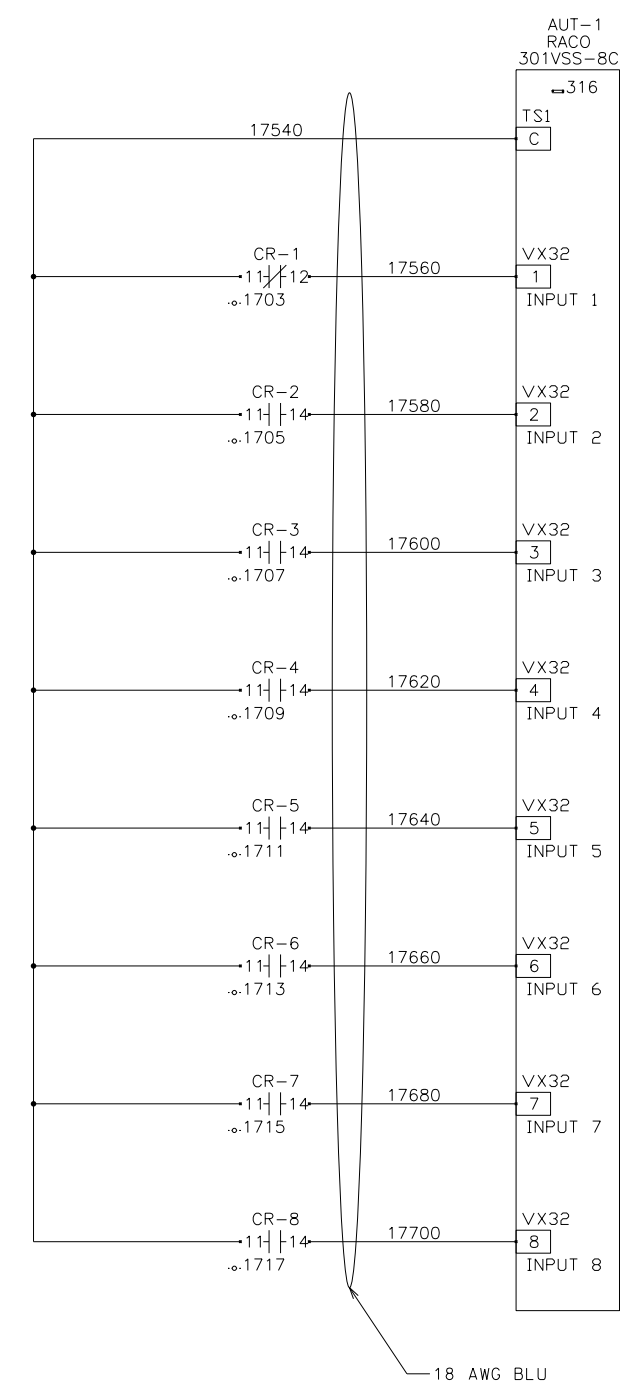

REV	DATE	PURPOSE:	BY	CHKD



DESIGNED RN	DATE 7/2013
DRAWN RN	DATE 7/2013
CHECKED DKS	DATE 08/2013

FOR:
YOUR CUSTOMER

THIS DRAWING, AND ALL REPRESENTED DATA, ARE THE PROPERTY OF THE NAMED COMPANY IN THE TITLE BLOCK. THIS DRAWING SHALL NOT BE REPRODUCED, COPIED, OR DISCLOSED EXCEPT FOR MAINTENANCE PURPOSES BY THE USING CUSTOMER.

CONTROL SCHEMATIC
WATER BOOSTER STATION
SCADA PANEL

DRAWING SET:
2012-398 SCADA PANEL

FIELD CONNECTIONS

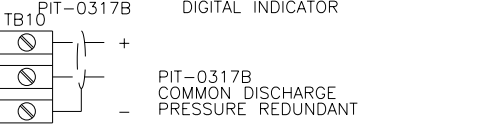
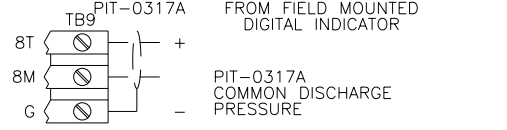
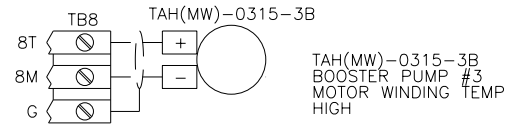
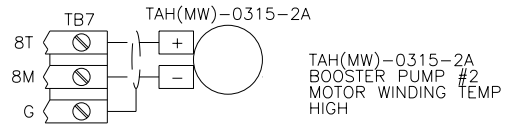
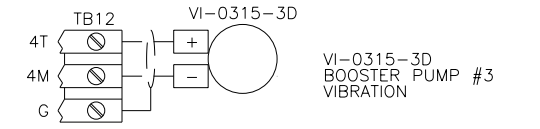
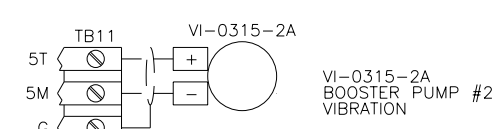
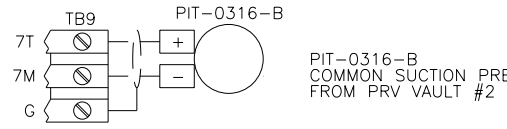
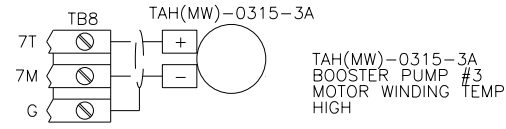
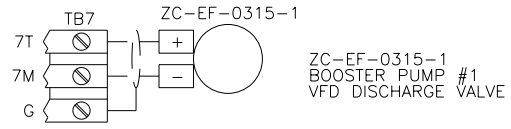
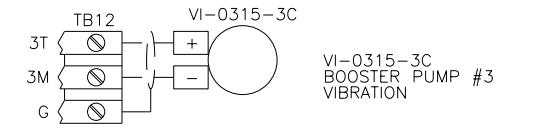
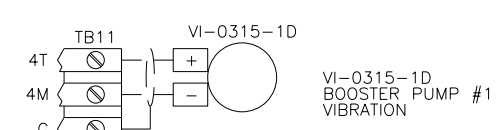
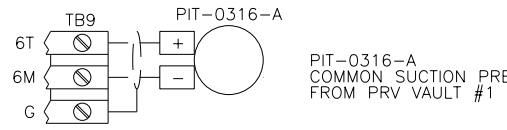
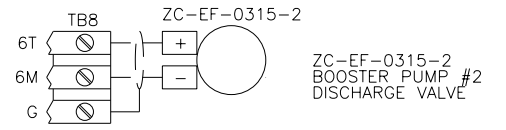
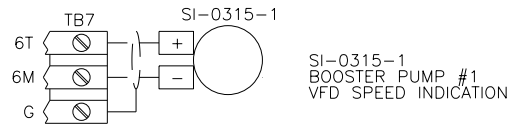
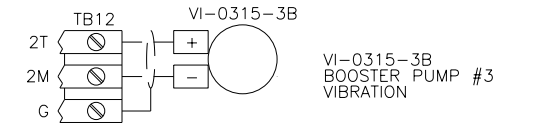
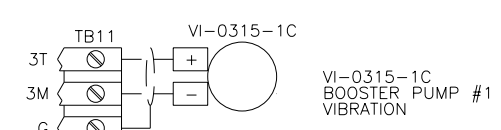
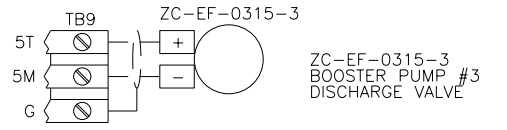
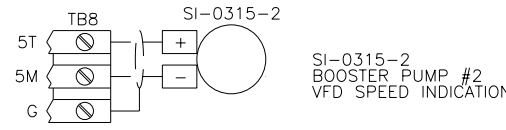
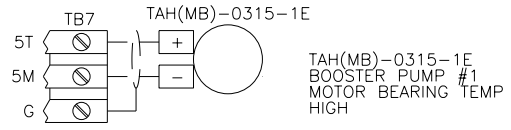
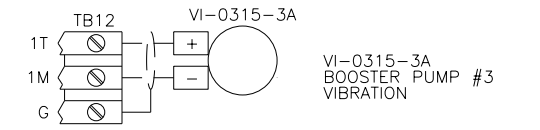
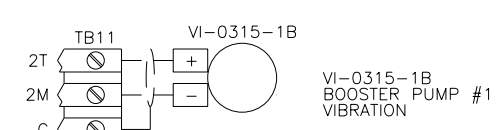
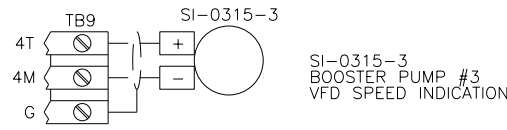
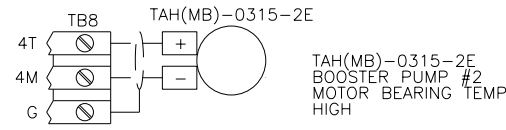
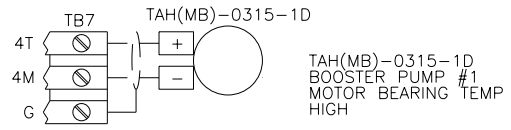
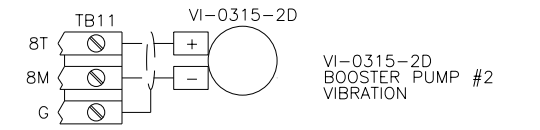
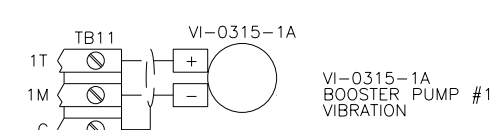
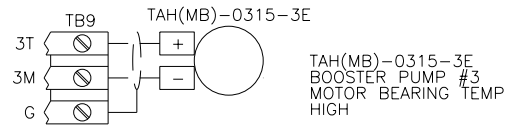
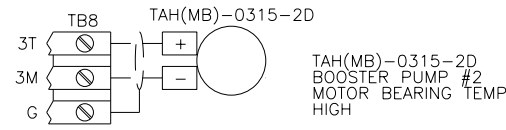
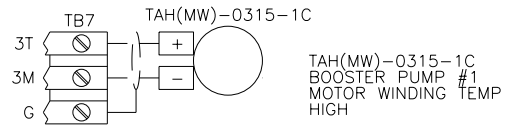
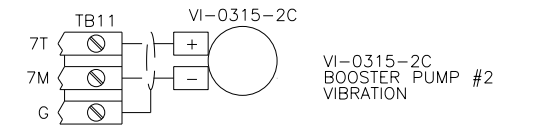
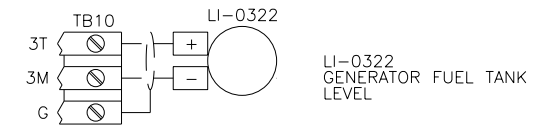
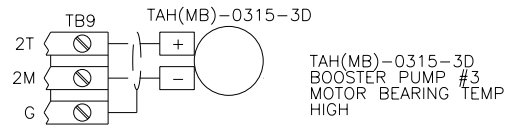
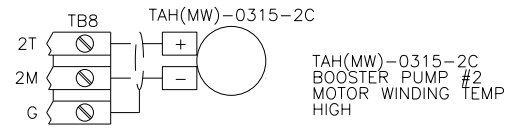
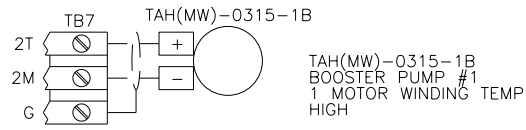
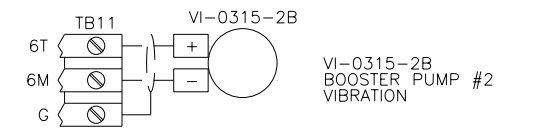
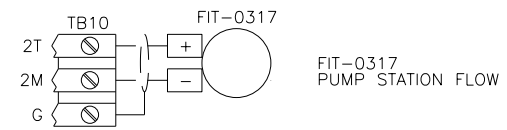
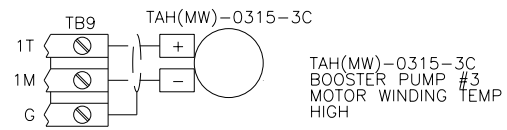
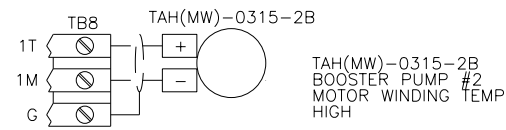
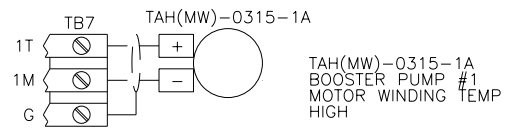

REV	DATE	PURPOSE:	BY	CHKD

YOUR COMPANY
 YOUR ADDRESS
 YOUR PHONE NO.
 YOUR WEBSITE

DESIGNED	DATE
RN	4/2013
DRAWN	DATE
RN	4/2013
CHECKED	DATE
DKS	08/2013

FOR: YOUR CUSTOMER

 THIS DRAWING, AND ALL REPRESENTED DATA, ARE THE PROPERTY OF THE NAMED COMPANY IN THE TITLE BLOCK. THIS DRAWING SHALL NOT BE REPRODUCED, COPIED, OR DISCLOSED EXCEPT FOR MAINTENANCE PURPOSES BY THE USING CUSTOMER.

FIELD CONNECTIONS
 WATER BOOSTER STATION
 SCADA PANEL

 DRAWING SET:
 2012-398 SCADA PANEL

FIELD CONNECTIONS

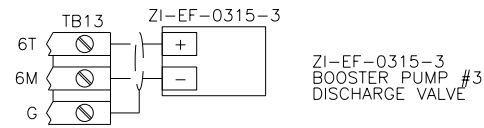
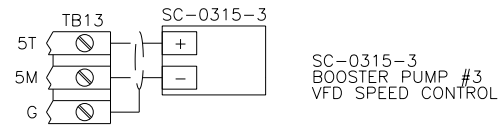
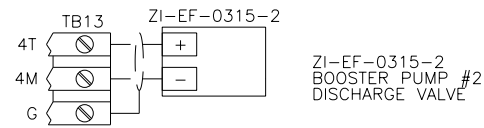
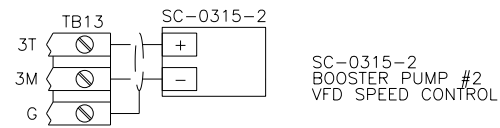
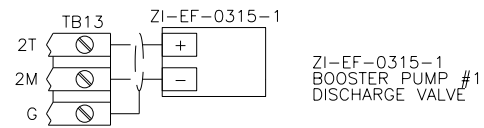
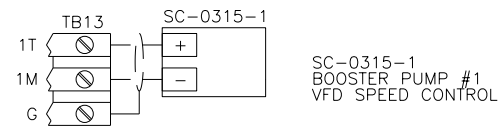

REV	DATE	PURPOSE:	BY	CHKD



YOUR COMPANY
YOUR ADDRESS
YOUR PHONE NO.
YOUR WEBSITE

DESIGNED RN	DATE 7/2013
DRAWN RN	DATE 7/2013
CHECKED DKS	DATE 08/2013

FOR:
YOUR CUSTOMER

THIS DRAWING, AND ALL REPRESENTED DATA, ARE THE PROPERTY OF THE NAMED COMPANY IN THE TITLE BLOCK. THIS DRAWING SHALL NOT BE REPRODUCED, COPIED, OR DISCLOSED EXCEPT FOR MAINTENANCE PURPOSES BY THE USING CUSTOMER.

FIELD CONNECTIONS
WATER BOOSTER STATION
SCADA PANEL

DRAWING SET:
2012-398 SCADA PANEL

NETWORK CONNECTIONS

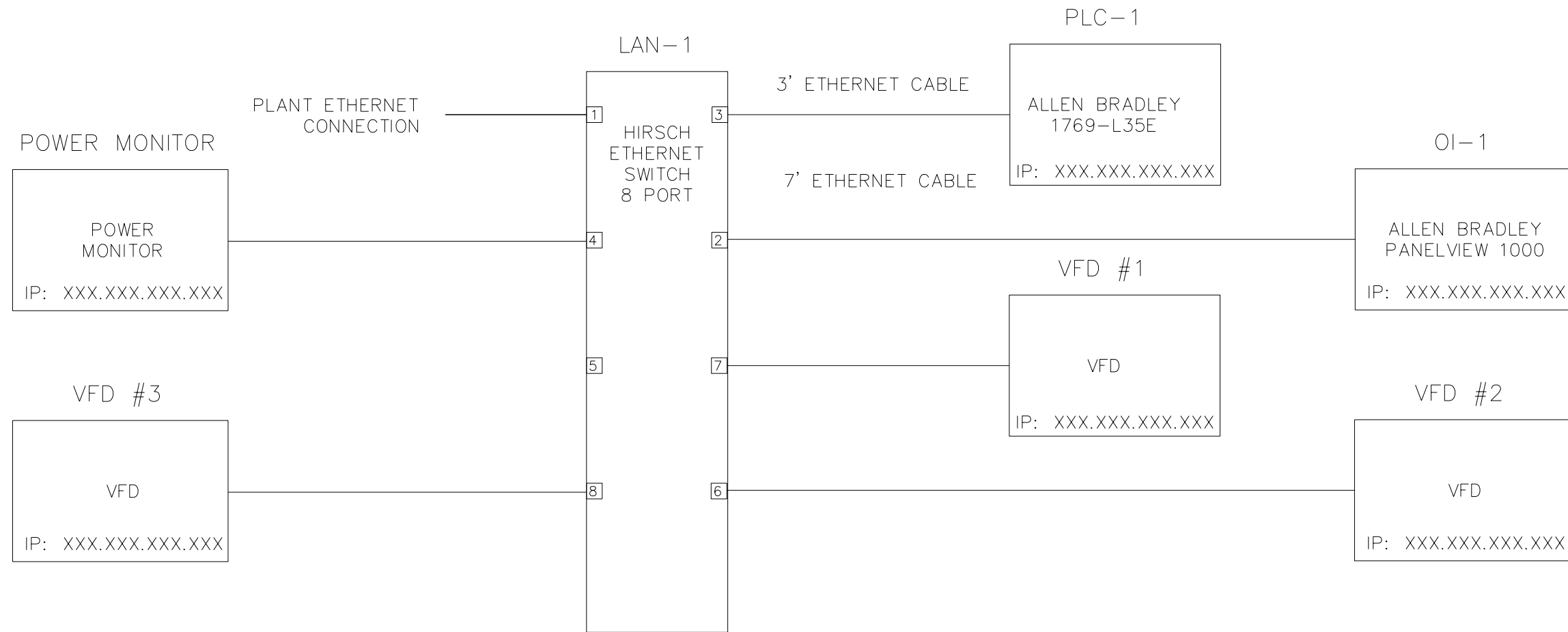

REV	DATE	PURPOSE:	BY	CHKD



YOUR COMPANY
 YOUR ADDRESS
 YOUR PHONE NO.
 YOUR WEBSITE

DESIGNED RN	DATE 06/2013
DRAWN RN	DATE 06/2013
CHECKED DKS	DATE 08/2013

FOR:
YOUR CUSTOMER

THIS DRAWING, AND ALL REPRESENTED DATA, ARE THE PROPERTY OF THE NAMED COMPANY IN THE TITLE BLOCK. THIS DRAWING SHALL NOT BE REPRODUCED, COPIED, OR DISCLOSED EXCEPT FOR MAINTENANCE PURPOSES BY THE USING CUSTOMER.

NETWORK DIAGRAM
 WATER BOOSTER STATION
 SCADA PANEL

DRAWING SET:
 2012-398 SCADA PANEL

Your Company

Project Name: Water Booster Station

Job No: 2012-398

Bill of Material

Panel Name: SCADA Panel

Typical of 4 Panel(s)

Device ID	Qty	Mfg	Part No	Description
ENCL-1	1	HO	A-724818-FSD	ENCL,NEMA 12,72X48X18,2 DOOR
PNL-1	1	HO	A-72P48-F1	BACKPANEL,72X48
CORH-1	1	HO	A-HCI10E	CORROSION INHIBITOR
SP-1	1	EDCO	EMC-240B	SURGE PROTECTOR,120/240V1PH,UL 1449
CB-M	1	AB	1489-A1C-250	CB,1P,480Y/277V,10KAIC,25A,C CURVE,DIN MNT
CB-CP	1	AB	1489-A1D-070	CB,1P,480Y/277V,10KAIC,07A,D CURVE,DIN MNT
LTG-1, LTG-2	2	HO	LED-A1S-35	LIGHT KIT,LED,090-260VAC,OFF-ON SWITCH,SCREW MNT
RCP-1, RCP-UPS	2	WEID	991548	RECEPT,1 OUTLET,DIN MNT
GB-1, GB-2, GB-3, GB-4	4	SD	PK9GTA	GROUND BAR KIT,ALUM,09 CKTS
CB-UPS	1	AB	1489-A1C-200	CB,1P,480Y/277V,10KAIC,20A,C CURVE,DIN MNT
UPS-1UPS	1	APC	SUM1500RML2U	UPS, APC SMART-UPS XL 1500VA, 1425W 120VAC, EXTENDED RUNTIME
CRD-1	1	ORION	24130-910-01	POWER CORD,3 C14 AWG,5-15P PLUG,15A
UPS-11	1	APC	AP9613	UPS, APC SMART SLOT RELAY I/O MODULE, AP9613
UPS-BYP	1	EATON	EHBPL1500R-PDU1U	UPS,FLEXPDU & HOTSWAP MBP, W/BYPASS SW
PWR-24	1	AB	1606-XLP-100E	PWR SUPP,120V TO 024VDC,DIN MNT,04.2A
PWR-12	1	AB	1606-XLP-30B	PWR SUPP,120V TO 010-12VDC,DIN MNT,03.0A,CLASS 2
ADD-1	1	RACO	301VSS-8C	AUTODIALER,VERBATIM,08 CH,120V, NEMA 1
CR-1, CR-2, CR-3, CR-4, CR-5, CR-6, CR-7, CR-8	8	AB	700-HLT1-L1-X	RELAY,1PDT,SLIM LINE,240V,6A,120V,GF,DIN MNT,LEAK SUPR
CRA-1	1	AB	700-TBJ20G	RELAY,1PDT,SLIM LINE,JUMPER BAR,20 POSITION
PLC-0	1	AB	1769-L35E	COMPACTLOGIX,PROCESSOR,1.5M,ENET/RS232
PLC-PS1, PLC-PS2	2	AB	1769-PA4	COMPACTLOGIX,POWER SUPPLY,4A,5V,120V
CBL-2BC	1	AB	1769-CRL3	COMPACTLOGIX,EXPANSION CABLE,RHT TO LFT,3 FT
PLC-ECR	1	AB	1769-ECR	COMPACTLOGIX,TERMINATOR,RIGHT END CAP
PLC-1, PLC-2, PLC-3, PLC-4	4	AB	1769-IA16	COMPACTLOGIX,INPUT,DIG,120V,16 PT
PLC-5, PLC-6	2	AB	1769-OA16	COMPACTLOGIX,OUTPUT,DIG,120V,16 PT
PLC-10, PLC-11, PLC-12, PLC-7, PLC-8, PLC-9	6	AB	1769-IF8	COMPACTLOGIX,INPUT,ANA,CURR/VOLT,08 PT
PLC-13	1	AB	1769-OF8C	COMPACTLOGIX,OUTPUT,ANA,CURR,8 PT
SP-AI1, SP-AI2	2	EDCO	DRS-036	SURGE PROTECTOR,DIN MNT,4-20mA
ES-1	1	HIRSH	943 376-001	ETHERNET SWITCH,SPIDER 8TX,8 PORT,24VDC

Your Company

Project Name: Water Booster Station

Job No: 2012-398

Bill of Material

LAN-PLC	1	QUIK	576-100-001	CABLE,CAT6,PATCH,GREY,UL,01 FT
LAN-MMI	1	QUIK	576-100-007	CABLE,CAT6,PATCH,GREY,UL,07 FT
OI-1	1	AB	2711P-T10C4A9	PANELVIEW+6 1000,TOUCH,COLOR,ENET/RS232,120V
RF-1	1	MDS	SD09-MDCMSNNSNN	RADIO,SD9,900 MHZ,9710 EMULATION,SERIAL,ENCL,FEM N,10-16VDC
RF-2	1	MDS	03-4125A04	RADIO,SD SERIES,DIN MOUNT BRACKET
RF-1D	1	MDS	9710-DIAG	RADIO,INSITE DIAGNOSTIC SOFTWARE
CBLR	1	CBLS2GO	02697	CABLE, DB9, MALE TO MALES,6FT
RF-RA	1	POLYPH	PS240-72NMNM	CABLE,HIFLEX,RG8X,900MHZ,N MALE TO N MALE,6 FT
RF-RA	1	POLYPH	IS-B50LN-C2	LIGHTNING ARR,BULKHEAD MNT,TYPE N FEM,BOTH ENDS
TB-	8	IDEC	BNL-5	END ANCHOR
TB-	3	AB	199-DR1	ACC,DIN RAIL,3FT
TB-	48	AB	1492-EAJ35	ACC,END ANCHOR
TB-	10	AB	1492-CJJ6-10	J 1 TIER,JUMPER,CTR,10 POLE,FOR J4
TB-	222	AB	1492-J4	J 1 TIER,TERMINAL,0.24 IN
TB-	3	AB	1492-JG4	J 1 TIER,TERMINAL,0.24 IN,GROUND
TB-	444	ACI	1492-M6X12-ACI	1 TIER,MARKER,BLANK,FOR 1492-J4
TB-	10	AB	1492-EBJ3	J 1 TIER,END BARRIER,FOR J3/J4/J10
TB-	56	AB	1492-JT3M	J,3 TIER,TERMINAL,0.20 IN,WITH GROUND
TB-	336	ACI	1492-M5X8-ACI	2 TIER,MARKER,BLANK,FOR 1492-JD3
TB-	11	AB	1492-EBTF3	W 3 TIER,END BARRIER,FOR WTF3
TB-	7	AB	1492-CJJ5-10	W 3 TIER,JUMPER,CTR,10 POLE